

TLE2142, TLE2142A, TLE2142Y EXCALIBUR LOW-NOISE HIGH-SPEED PRECISION DUAL OPERATIONAL AMPLIFIERS

SLOS064B – DECEMBER 1990 – REVISED AUGUST 1994

- **Low Noise**
10 Hz . . . 15 nV/√Hz
1 kHz . . . 10.5 nV/√Hz
- **10000-pF Load Capability**
- **20-mA Min Short-Circuit Output Current**
- **27-V/μs Min Slew Rate**
- **High Gain-Bandwidth Product . . . 5.9 MHz**
- **Low V_{IO} . . . 750 μV Max at 25°C**
- **Single or Split Supply**
- **Fast Settling Time**
340 ns to 0.1%
400 ns to 0.01%
- **Saturation Recovery . . . 150 ns**
- **Large Output Swing**
 $V_{CC-} + 0.1 \text{ V}$ to $V_{CC+} - 1 \text{ V}$

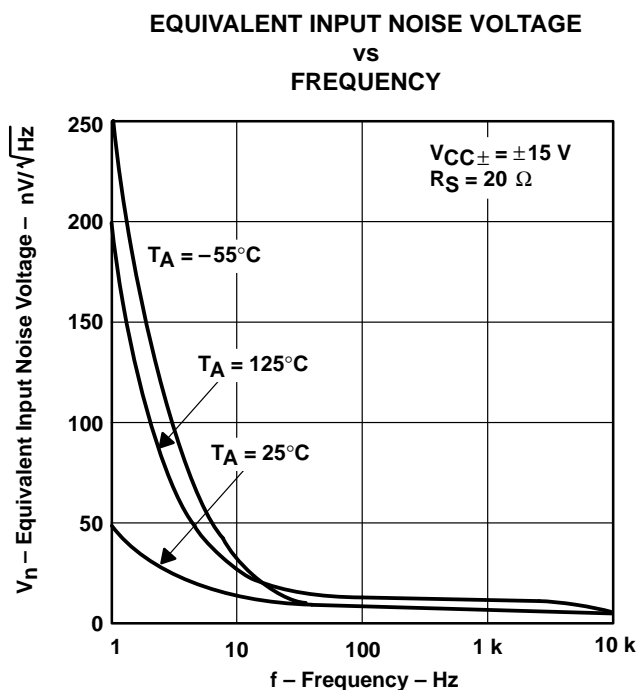
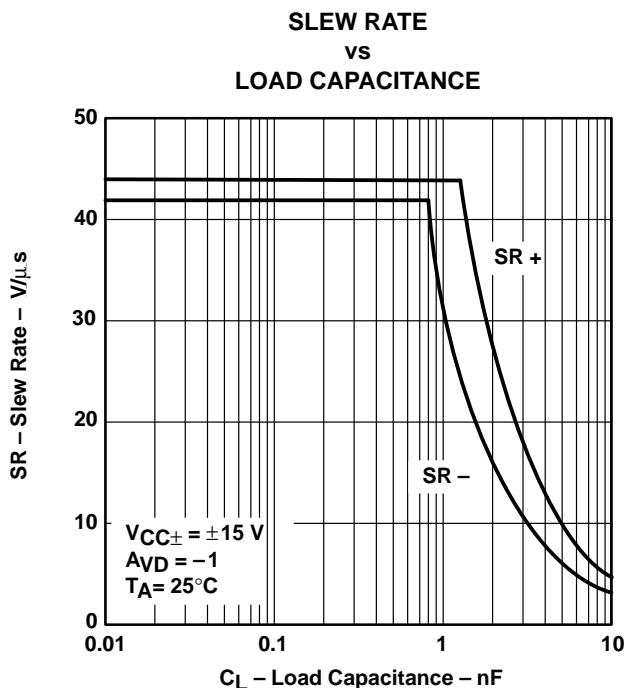

description

The TLE2142 and TLE2142A devices are high-performance internally-compensated operational amplifiers built using Texas Instruments complementary bipolar Excalibur process. The TLE2142A is a tighter offset voltage grade of the TLE2142. Both are pin-compatible upgrades to standard industry products.

AVAILABLE OPTIONS

| PACKAGED DEVICES | | | | | | CHIP FORM (Y) |
|------------------|---------------------|-------------------|-------------------|------------------|-----------------|---------------|
| T_A | V_{IOmax} AT 25°C | SMALL OUTLINE (D) | CHIP CARRIER (FK) | CERAMIC DIP (JG) | PLASTIC DIP (P) | |
| 0°C to 70°C | 750 μV | TLE2142ACD | — | — | TLE2142ACP | — |
| | 1200 μV | TLE2142CD | — | — | TLE2142CP | |
| -40°C to 105°C | 750 μV | TLE2142AID | — | — | TLC2142AIP | TLE2142Y |
| | 1200 μV | TLE2142ID | — | — | TLC2142IP | |
| -55°C to 125°C | 750 μV | TLE2142AMD | TLE2142AMFK | TLE2142AMJG | TLC2142AMP | — |
| | 1200 μV | TLE2142MD | TLE2142MFK | TLE2142MJG | TLC2142MP | |

The D packages are available taped and reeled. Add R suffix to device type (e.g., TLC2142ACDR).

PRODUCTION DATA information is current as of publication date. Products conform to specifications per the terms of Texas Instruments standard warranty. Production processing does not necessarily include testing of all parameters.



POST OFFICE BOX 655303 • DALLAS, TEXAS 75265

Copyright © 1994, Texas Instruments Incorporated

TLE2142, TLE2142A, TLE2142Y EXCALIBUR LOW-NOISE HIGH-SPEED PRECISION DUAL OPERATIONAL AMPLIFIERS

SLOS064B – DECEMBER 1990 – REVISED AUGUST 1994

description (continued)

The design incorporates a patent-pending input stage that simultaneously achieves low audio-band noise of $10.5 \text{ nV}/\sqrt{\text{Hz}}$, with a 6-Hz $1/f$ corner and symmetrical $40\text{-V}/\mu\text{s}$ slew rate typically with loads up to 800 pF. The resulting low distortion and high power bandwidth are important in high-fidelity audio applications. A fast settling time of 340 ns to 0.1% of a 10-V step with a $2\text{-k}\Omega/100\text{-pF}$ load is useful in fast actuator/positioning drivers. Under similar test conditions, settling time to 0.01% is 400 ns.

The devices are stable with capacitive loads up to 10 nF, although the 6-MHz bandwidth decreases to 1.8 MHz at this high loading level. As such, the TLE2142 and TLE2142A are useful for low-droop sample-and-holds and direct buffering of long cables, including 4-mA to 20-mA current loops.

The special design also exhibits an improved insensitivity to inherit integrated circuit component mismatches as is evidenced by a $750\text{-}\mu\text{V}$ maximum offset voltage and $1.7\text{-}\mu\text{V}/^\circ\text{C}$ typical drift. Minimum common-mode rejection ratio and supply voltage rejection ratio are 85 dB and 90 dB, respectively.

Device performance is relatively independent of supply voltage over the $\pm 2\text{-V}$ to $\pm 22\text{-V}$ range. Inputs can operate between $V_{CC-} - 0.3$ to $V_{CC+} - 1.8$ V without inducing phase reversal, although excessive input current may flow out of each input exceeding the lower common-mode input range. The all-npn output stage provides a nearly rail-to-rail output swing of $V_{CC-} + 0.1$ to $V_{CC+} - 1$ V under light current-loading conditions. The device can sustain shorts to either supply since output current is internally limited, but care must be taken to ensure that maximum package power dissipation is not exceeded.

Both versions can also be used as comparators. Differential inputs of $V_{CC\pm}$ can be maintained without damage to the device. Open-loop propagation delay with TTL supply levels is typically 200 ns. This gives a good indication as to output stage saturation recovery when the device is driven beyond the limits of recommended output swing.

Both the TLE2142 and TLE2142A are available in a wide variety of packages, including both the industry-standard 8-pin small-outline version and chip form for high-density system applications. The C-suffix devices are characterized for operation from 0°C to 70°C , I-suffix devices from -40°C to 105°C , and M-suffix devices over the full military temperature range of -55°C to 125°C .

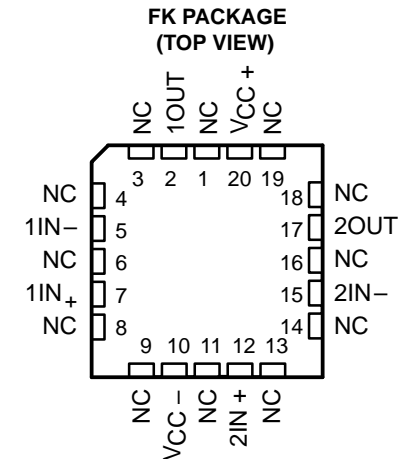
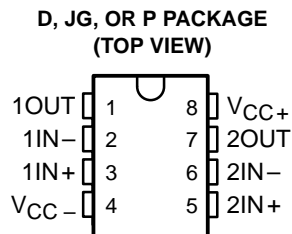

NC – No internal connection

symbol (each amplifier)

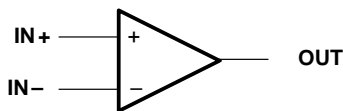

TLE2142Y chip information

This chip, when properly assembled, displays characteristics similar to the TLE2142. Thermal compression or ultrasonic bonding may be used on the doped-aluminum bonding pads. Chips may be mounted with conductive epoxy or a gold-silicon preform.

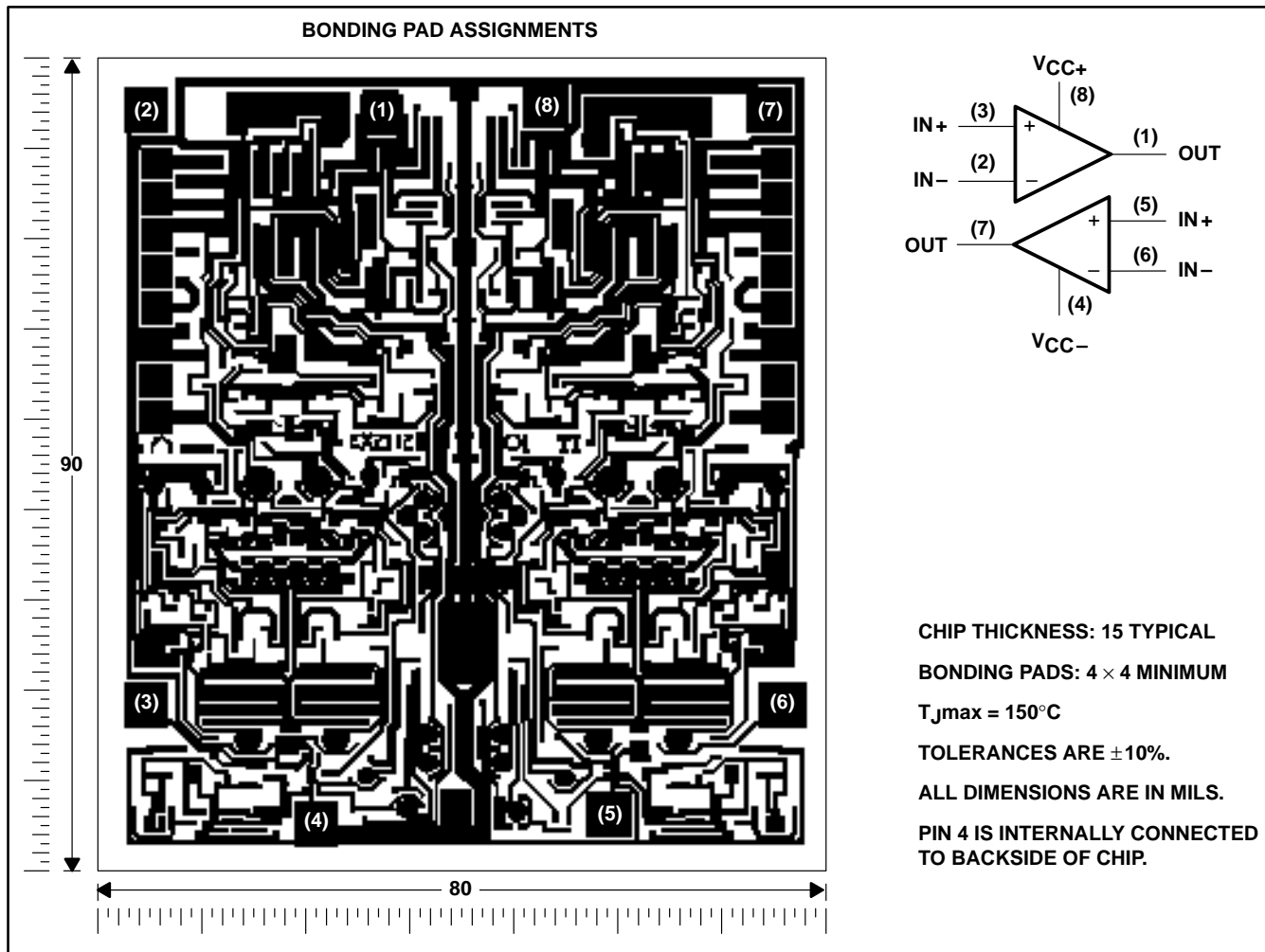

TLE2142, TLE2142A, TLE2142Y
 EXCALIBUR LOW-NOISE HIGH-SPEED
 PRECISION DUAL OPERATIONAL AMPLIFIERS
 SLOS064B – DECEMBER 1990 – REVISED AUGUST 1994

equivalent schematic (per amplifier)

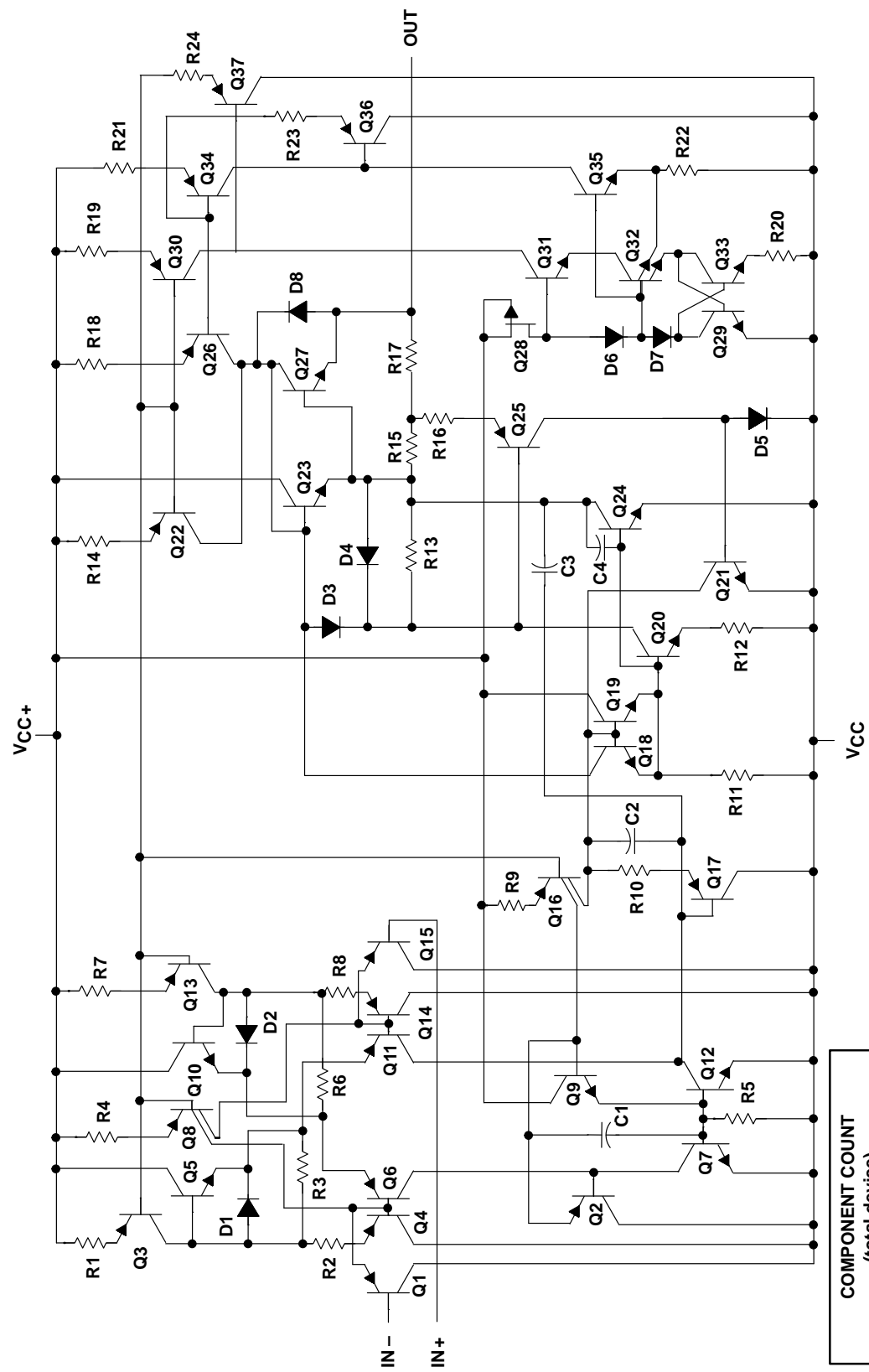

| COMPONENT COUNT (total device) | |
|-----------------------------------|----|
| Transistors | 65 |
| Epi-FET | 1 |
| Diodes | 14 |
| Resistors | 43 |
| Capacitors | 8 |



absolute maximum ratings over operating free-air temperature range (unless otherwise noted)†

| | |
|--|--------------------------------|
| Supply voltage, V_{CC+} (see Note 1) | 22 V |
| Supply voltage, V_{CC-} | -22 V |
| Differential input voltage, V_{ID} (see Note 2) | V_{CC+} to V_{CC-} |
| Input voltage range, V_I (any input) | V_{CC+} to $V_{CC-} - 0.3$ V |
| Input current, I_I (each input) | ± 1 mA |
| Output current, I_O | ± 80 mA |
| Total current into V_{CC+} | 160 mA |
| Total current out of V_{CC-} | 160 mA |
| Duration of short-circuit current at (or below) 25°C (see Note 3) | unlimited |
| Continuous total dissipation | See Dissipation Rating Table |
| Operating free-air temperature range, T_A : C suffix | 0°C to 70°C |
| I suffix | -40°C to 105°C |
| M suffix | -55°C to 125°C |
| Storage temperature range | -65°C to 150°C |
| Case temperature for 60 seconds: FK package | 260°C |
| Lead temperature 1,6 mm (1/16 inch) from case for 10 seconds: D or P package | 260°C |
| Lead temperature 1,6 mm (1/16 inch) from case for 60 seconds: JG package | 300°C |

† Stresses beyond those listed under “absolute maximum ratings” may cause permanent damage to the device. These are stress ratings only, and functional operation of the device at these or any other conditions beyond those indicated under “recommended operating conditions” is not implied. Exposure to absolute-maximum-rated conditions for extended periods may affect device reliability.

- NOTES: 1. All voltage values, except differential voltages, are with respect to the midpoint between V_{CC+} and V_{CC-} .
 2. Differential voltages are at $IN+$ with respect to $IN-$. Excessive current will flow if input is brought below $V_{CC-} - 0.3$ V.
 3. The output may be shorted to either supply. Temperature and/or supply voltages must be limited to ensure that the maximum dissipation rating is not exceeded.

DISSIPATION RATING TABLE

| PACKAGE | $T_A \leq 25^\circ\text{C}$ | DERATING FACTOR ABOVE $T_A = 25^\circ\text{C}$ | $T_A = 70^\circ\text{C}$ | $T_A = 105^\circ\text{C}$ | $T_A = 125^\circ\text{C}$ |
|---------|-----------------------------|---|--------------------------|---------------------------|---------------------------|
| | POWER RATING | | POWER RATING | POWER RATING | POWER RATING |
| D | 725 mW | 5.8 mW/°C | 464 mW | 261 mW | 145 mW |
| FK | 1375 mW | 11.0 mW/°C | 880 mW | 495 mW | 275 mW |
| JG | 1050 mW | 8.4 mW/°C | 672 mW | 378 mW | 210 mW |
| P | 1000 mW | 8.0 mW/°C | 640 mW | 360 mW | 200 mW |

recommended operating conditions

| | C SUFFIX | | I SUFFIX | | M SUFFIX | | UNIT |
|---------------------------------------|------------------------|----------|----------|----------|----------|----------|------|
| | MIN | MAX | MIN | MAX | MIN | MAX | |
| Supply voltage, $V_{CC\pm}$ | ± 2 | ± 22 | ± 2 | ± 22 | ± 2 | ± 22 | V |
| Common-mode input voltage, V_{IC} | $V_{CC} = 5$ V | | 0 | 2.9 | 0 | 2.7 | V |
| | $V_{CC\pm} = \pm 15$ V | | -15 | 12.9 | -15 | 12.7 | |
| Operating free-air temperature, T_A | 0 | 70 | -40 | 105 | -55 | 125 | °C |

TLE2142, TLE2142A, TLE2142Y
EXCALIBUR LOW-NOISE HIGH-SPEED
PRECISION DUAL OPERATIONAL AMPLIFIERS

SLOS064B – DECEMBER 1990 – REVISED AUGUST 1994

electrical characteristics at specified free-air temperature, $V_{CC} = 5\text{ V}$ (unless otherwise noted)

| PARAMETER | TEST CONDITIONS | T_A † | TLE2142C | | | TLE2142AC | | | UNIT |
|---|--|------------|----------|-------------|------|-----------|-------------|------------------------------|---------------|
| | | | MIN | TYP | MAX | MIN | TYP | MAX | |
| V_{IO} Input offset voltage | $V_O = 2.5\text{ V}$, $V_{IC} = 2.5\text{ V}$ $R_S = 50\ \Omega$ | 25°C | 220 | 1900 | | 200 | 1500 | μV | |
| | | Full range | | | 2200 | | 1800 | | |
| α_{VIO} Temperature coefficient of input offset voltage | | Full range | | 1.7 | | | 1.7 | $\mu\text{V}/^\circ\text{C}$ | |
| I_{IO} Input offset current | | 25°C | | 8 | 100 | | 8 | 100 | nA |
| | | Full range | | | 150 | | | 150 | |
| I_{IB} Input bias current | | 25°C | | -0.8 | -2 | | -0.8 | -2 | μA |
| | Full range | | | -2.1 | | | -2.1 | | |
| V_{ICR} Common-mode input voltage range | $R_S = 50\ \Omega$ | 25°C | 0 to 3 | -0.3 to 3.2 | | 0 to 3 | -0.3 to 3.2 | V | |
| | | Full range | 0 to 2.9 | | | 0 to 2.9 | | | |
| V_{OH} High-level output voltage | $I_{OH} = -150\ \mu\text{A}$ | 25°C | 3.9 | 4.1 | | 3.9 | 4.1 | V | |
| | | Full range | | 3.8 | | | 3.8 | | |
| | $I_{OH} = -1.5\text{ mA}$ | 25°C | 3.8 | 4 | | 3.8 | 4 | | |
| | | Full range | | 3.7 | | | 3.7 | | |
| | $I_{OH} = -15\text{ mA}$ | 25°C | 3.4 | 3.7 | | 3.4 | 3.7 | | |
| | | Full range | | 3.4 | | | 3.4 | | |
| V_{OL} Low-level output voltage | $I_{OL} = 150\ \mu\text{A}$ | 25°C | | 75 | 125 | | 75 | 125 | mV |
| | | Full range | | | 150 | | | 150 | |
| | $I_{OL} = 1.5\text{ mA}$ | 25°C | | 150 | 225 | | 150 | 225 | |
| | | Full range | | | 250 | | | 250 | |
| | $I_{OL} = 15\text{ mA}$ | 25°C | | 1.2 | 1.4 | | 1.2 | 1.4 | V |
| | | Full range | | | 1.5 | | | 1.5 | |
| A_{VD} Large-signal differential voltage amplification | $V_{CC} = \pm 2.5\text{ V}$, $R_L = 2\text{ k}\Omega$, $V_O = 1\text{ V to } -1.5\text{ V}$ | 25°C | 50 | 220 | | 50 | 220 | V/mV | |
| | | Full range | | 25 | | | 25 | | |
| r_i Input resistance | | 25°C | | 70 | | | 70 | M Ω | |
| c_i Input capacitance | | 25°C | | 2.5 | | | 2.5 | pF | |
| z_o Open-loop output impedance | $f = 1\text{ MHz}$ | 25°C | | 30 | | | 30 | Ω | |
| CMRR Common-mode rejection ratio | $V_{IC} = V_{ICRmin}$, $R_S = 50\ \Omega$ | 25°C | 85 | 118 | | 85 | 118 | dB | |
| | | Full range | | 80 | | | 80 | | |
| k_{SVR} Supply-voltage rejection ratio ($\Delta V_{CC\pm} / \Delta V_{IO}$) | $V_{CC\pm} = \pm 2.5\text{ V to } \pm 15\text{ V}$, $R_S = 50\ \Omega$ | 25°C | 90 | 106 | | 90 | 106 | dB | |
| | | Full range | | 85 | | | 85 | | |
| I_{CC} Supply current | $V_O = 2.5\text{ V}$, $V_{IC} = 2.5\text{ V}$ No load, | 25°C | | 6.6 | 8.8 | | 6.6 | 8.8 | mA |
| | | Full range | | | 9.2 | | | 9.2 | |

† Full range is 0°C to 70°C.



TLE2142, TLE2142A, TLE2142Y
EXCALIBUR LOW-NOISE HIGH-SPEED
PRECISION DUAL OPERATIONAL AMPLIFIERS
 SLOS064B – DECEMBER 1990 – REVISED AUGUST 1994

operating characteristics, $V_{CC} = 5\text{ V}$, $T_A = 25^\circ\text{C}$

| PARAMETER | | TEST CONDITIONS | | TLE2142C | | | TLE2142AC | | | UNIT |
|-------------|---|--|--|---|-----|---------|------------------------|-----|------------------|------|
| | | | | MIN | TYP | MAX | MIN | TYP | MAX | |
| SR+ | Positive slew rate | $A_{VD} = -1$, $C_L = 500\text{ pF}$ | | $R_L = 2\text{ k}\Omega^\dagger$ | | 45 | | | V/ μs | |
| SR- | Negative slew rate | | | | | 42 | | | | |
| t_s | Settling time | $A_{VD} = -1$, 2.5-V step | | To 0.1% | | 0.16 | | | μs | |
| | | | | To 0.01% | | 0.22 | | | | |
| V_n | Equivalent input noise voltage | $R_S = 20\ \Omega$, $f = 10\text{ Hz}$ | | 15 | | | nV/ $\sqrt{\text{Hz}}$ | | | |
| | | $R_S = 20\ \Omega$, $f = 1\text{ kHz}$ | | 10.5 | | | | | | |
| $V_{N(PP)}$ | Peak-to-peak equivalent input noise voltage | $f = 0.1\text{ Hz to }1\text{ Hz}$ | | 0.48 | | | μV | | | |
| | | $f = 0.1\text{ Hz to }10\text{ Hz}$ | | 0.51 | | | | | | |
| I_n | Equivalent input noise current | $f = 10\text{ Hz}$ | | 1.92 | | | pA/ $\sqrt{\text{Hz}}$ | | | |
| | | $f = 1\text{ kHz}$ | | 0.5 | | | | | | |
| THD + N | Total harmonic distortion plus noise | $V_O = 1\text{ V to }3\text{ V}$, $A_{VD} = 2$ | | $R_L = 2\text{ k}\Omega^\dagger$, $f = 10\text{ kHz}$ | | 0.0052% | | | | |
| B1 | Unity-gain bandwidth | $R_L = 2\text{ k}\Omega^\dagger$ | | $C_L = 100\text{ pF}$ | | 5.9 | | | MHz | |
| | Gain-bandwidth product | $R_L = 2\text{ k}\Omega^\dagger$, $f = 100\text{ kHz}$ | | $C_L = 100\text{ pF}$ | | 5.8 | | | MHz | |
| B_{OM} | Maximum output-swing bandwidth | $V_{O(PP)} = 2\text{ V}$, $A_{VD} = 1$ | | $R_L = 2\text{ k}\Omega^\dagger$, $C_L = 100\text{ pF}$ | | 660 | | | kHz | |
| ϕ_m | Phase margin at unity gain | $R_L = 2\text{ k}\Omega^\dagger$ | | $C_L = 100\text{ pF}$ | | 57° | | | | |

$^\dagger R_L$ terminates at 2.5 V.

TLE2142, TLE2142A, TLE2142Y
EXCALIBUR LOW-NOISE HIGH-SPEED
PRECISION DUAL OPERATIONAL AMPLIFIERS

SLOS064B – DECEMBER 1990 – REVISED AUGUST 1994

electrical characteristics at specified free-air temperature, $V_{CC\pm} = \pm 15$ V (unless otherwise noted)

| PARAMETER | TEST CONDITIONS | T_A † | TLE2142C | | | TLE2142AC | | | UNIT | |
|---|---|-----------------------------------|------------|---------------|---------------|-----------|---------------|-------|---------------|----|
| | | | MIN | TYP | MAX | MIN | TYP | MAX | | |
| V_{IO} Input offset voltage | | 25°C | | 290 | 1200 | | 275 | 750 | μ V | |
| | | Full range | | | 1600 | | | 1200 | | |
| α_{VIO} Temperature coefficient of input offset voltage | $V_{IC} = 0,$ $V_O = 0$ | $R_S = 50 \Omega,$ | Full range | | 1.7 | | 1.7 | | μ V/°C | |
| I_{IO} Input offset current | | | 25°C | | 7 | 100 | | 7 | 100 | nA |
| | Full range | | | 150 | | | 150 | | | |
| I_{IB} Input bias current | | 25°C | | -0.7 | -1.5 | | -0.7 | -1.5 | μ A | |
| | | Full range | | | -1.6 | | | -1.6 | | |
| V_{ICR} Common-mode input voltage range | $R_S = 50 \Omega$ | 25°C | -15 to 13 | -15.3 to 13.2 | | -15 to 13 | -15.3 to 13.2 | V | | |
| | | Full range | | -15 to 12.9 | -15.3 to 13.1 | | -15 to 12.9 | | -15.3 to 13.1 | |
| V_{OM+} Maximum positive peak output voltage swing | $I_O = -150 \mu$ A | 25°C | | 13.8 | 14.1 | | 13.8 | 14.1 | V | |
| | | Full range | | | 13.7 | | | 13.7 | | |
| | $I_O = -1.5$ mA | 25°C | | 13.7 | 14 | | 13.7 | 14 | | |
| | | Full range | | | 13.6 | | | 13.6 | | |
| $I_O = -15$ mA | 25°C | | 13.3 | 13.7 | | 13.3 | 13.7 | | | |
| | Full range | | | 13.2 | | | 13.2 | | | |
| V_{OM-} Maximum negative peak output voltage swing | $I_O = 150 \mu$ A | 25°C | | -14.7 | -14.9 | | -14.7 | -14.9 | V | |
| | | Full range | | | -14.6 | | | -14.6 | | |
| | $I_O = 1.5$ mA | 25°C | | -14.5 | -14.8 | | -14.5 | -14.8 | | |
| | | Full range | | | -14.4 | | | -14.4 | | |
| $I_O = 15$ mA | 25°C | | -13.4 | -13.8 | | -13.4 | -13.8 | | | |
| | Full range | | | -13.3 | | | -13.3 | | | |
| A_{VD} Large-signal differential voltage amplification | $V_O = \pm 10$ V | 25°C | | 100 | 450 | | 100 | 450 | V/mV | |
| | | Full range | | | 75 | | | 75 | | |
| r_i Input resistance | $R_L = 2$ k Ω | 25°C | | | 65 | | | 65 | M Ω | |
| c_i Input capacitance | | 25°C | | | 2.5 | | | 2.5 | pF | |
| z_o Open-loop output impedance | $f = 1$ MHz | 25°C | | | 30 | | | 30 | Ω | |
| CMRR Common-mode rejection ratio | $V_{IC} = V_{ICRmin},$ $R_S = 50 \Omega$ | 25°C | | 85 | 108 | | 85 | 108 | dB | |
| | | Full range | | | 80 | | | 80 | | |
| k_{SVR} Supply-voltage rejection ratio ($\Delta V_{CC\pm} / \Delta V_{IO}$) | $V_{CC\pm} = \pm 2.5$ V to ± 15 V, $R_S = 50 \Omega$ | 25°C | | 90 | 106 | | 90 | 106 | dB | |
| | | Full range | | | 85 | | | 85 | | |
| I_{OS} Short-circuit output current | $V_O = 0$ | $V_{ID} = 1$ V $V_{ID} = -1$ V | 25°C | -25 | -50 | | -25 | -50 | mA | |
| | | | | 20 | 31 | | 20 | 31 | | |
| I_{CC} Supply current | $V_O = 0,$ No load | | 25°C | | 6.9 | 9 | | 6.9 | 9 | mA |
| | | | Full range | | | 9.4 | | | 9.4 | |

† Full range is 0°C to 70°C.



TLE2142, TLE2142A, TLE2142Y
EXCALIBUR LOW-NOISE HIGH-SPEED
PRECISION DUAL OPERATIONAL AMPLIFIERS
 SLOS064B – DECEMBER 1990 – REVISED AUGUST 1994

operating characteristics, $V_{CC\pm} = \pm 15\text{ V}$, $T_A = 25^\circ\text{C}$

| PARAMETER | TEST CONDITIONS | TLE2142C | | | TLE2142AC | | | UNIT | |
|-------------|---|--|---|--------------------------|-----------|------------------------|------------------------|------|------------------|
| | | MIN | TYP | MAX | MIN | TYP | MAX | | |
| SR+ | Positive slew rate | $A_{VD} = -1$, $C_L = 500\text{ pF}$ | | $R_L = 2\text{ k}\Omega$ | 27 | 45 | 27 | 45 | V/ μs |
| SR- | Negative slew rate | | | | 27 | 42 | 27 | 42 | |
| t_s | Settling time | $A_{VD} = -1$, 10-V step | To 0.1% | 0.34 | | | μs | | |
| | | | To 0.01% | 0.4 | | | | | |
| V_n | Equivalent input noise voltage | $R_S = 20\ \Omega$, $f = 10\text{ Hz}$ | 15 | | | nV/ $\sqrt{\text{Hz}}$ | | | |
| | | $R_S = 20\ \Omega$, $f = 1\text{ kHz}$ | 10.5 | | | | | | |
| $V_{N(PP)}$ | Peak-to-peak equivalent input noise voltage | $f = 0.1\text{ Hz to }1\text{ Hz}$ | | 0.48 | | | μV | | |
| | | $f = 0.1\text{ Hz to }10\text{ Hz}$ | | 0.51 | | | | | |
| I_n | Equivalent input noise current | $f = 10\text{ Hz}$ | | 1.89 | | | pA/ $\sqrt{\text{Hz}}$ | | |
| | | $f = 1\text{ kHz}$ | | 0.47 | | | | | |
| THD + N | Total harmonic distortion plus noise | $V_{O(PP)} = 20\text{ V}$, $A_{VD} = 10$, | $R_L = 2\text{ k}\Omega$, $f = 10\text{ kHz}$ | 0.01% | | | | | |
| B_1 | Unity-gain bandwidth | $R_L = 2\text{ k}\Omega$, | $C_L = 100\text{ pF}$ | 6 | | | MHz | | |
| | Gain-bandwidth product | $R_L = 2\text{ k}\Omega$, $f = 100\text{ kHz}$ | $C_L = 100\text{ pF}$ | 5.9 | | | MHz | | |
| B_{OM} | Maximum output-swing bandwidth | $V_{O(PP)} = 20\text{ V}$, $A_{VD} = 1$, | $R_L = 2\text{ k}\Omega$, $C_L = 100\text{ pF}$ | 668 | | | kHz | | |
| ϕ_m | Phase margin at unity gain | $R_L = 2\text{ k}\Omega$, | $C_L = 100\text{ pF}$ | 58° | | | | | |

TLE2142, TLE2142A, TLE2142Y
EXCALIBUR LOW-NOISE HIGH-SPEED
PRECISION DUAL OPERATIONAL AMPLIFIERS

SLOS064B – DECEMBER 1990 – REVISED AUGUST 1994

electrical characteristics at specified free-air temperature, $V_{CC} = 5\text{ V}$ (unless otherwise noted)

| PARAMETER | TEST CONDITIONS | T_A † | TLE2142I | | | TLE2142AI | | | UNIT | |
|---|---|------------|----------|-------------|------|-----------|-------------|------------|------------------------------|--|
| | | | MIN | TYP | MAX | MIN | TYP | MAX | | |
| V_{IO} Input offset voltage | $V_O = 2.5\text{ V}$, $V_{IC} = 2.5\text{ V}$ $R_S = 50\ \Omega$ | 25°C | | 220 | 1900 | | 220 | 1500 | μV | |
| | | Full range | | | 2400 | | | 2000 | | |
| α_{VIO} Temperature coefficient of input offset voltage | | Full range | | 1.7 | | | 1.7 | | $\mu\text{V}/^\circ\text{C}$ | |
| I_{IO} Input offset current | | 25°C | | 8 | 100 | | 8 | 100 | nA | |
| | | Full range | | | 200 | | | 200 | | |
| I_{IB} Input bias current | | 25°C | | -0.8 | -2 | | -0.8 | -2 | μA | |
| | Full range | | | -2.2 | | | -2.2 | | | |
| V_{ICR} Common-mode input voltage range | $R_S = 50\ \Omega$ | 25°C | 0 to 3 | -0.3 to 3.2 | | 0 to 3 | -0.3 to 3.2 | V | | |
| | | Full range | 0 to 2.7 | -0.3 to 2.9 | | 0 to 2.7 | -0.3 to 2.9 | | | |
| V_{OH} High-level output voltage | $I_{OH} = -150\ \mu\text{A}$ $I_{OH} = -1.5\text{ mA}$ $I_{OH} = -15\text{ mA}$ $I_{OH} = 100\ \mu\text{A}$ $I_{OH} = 1\text{ mA}$ $I_{OH} = 10\text{ mA}$ | 25°C | | 3.9 | 4.1 | | 3.9 | 4.1 | V | |
| | | | | 3.8 | 4 | | 3.8 | 4 | | |
| | | | | 3.4 | 3.7 | | 3.4 | 3.7 | | |
| | | Full range | | 3.8 | | | 3.8 | | | |
| | | | | 3.7 | | | 3.7 | | | |
| | | | | 3.5 | | | 3.5 | | | |
| V_{OL} Low-level output voltage | $I_{OL} = 150\ \mu\text{A}$ $I_{OL} = 1.5\text{ mA}$ $I_{OL} = 15\text{ mA}$ $I_{OL} = 100\ \mu\text{A}$ $I_{OL} = 1\text{ mA}$ $I_{OL} = 10\text{ mA}$ | 25°C | | 75 | 125 | | 75 | 125 | mV | |
| | | | | 150 | 225 | | 150 | 225 | | |
| | | | | 1.2 | 1.4 | | 1.2 | 1.4 | | |
| | | Full range | | 175 | | | 175 | | | |
| | | | | 225 | | | 225 | | | |
| | | | | 1.2 | | | 1.2 | | | |
| A_{VD} Large-signal differential voltage amplification | $V_{IC} = \pm 2.5\text{ V}$, $V_O = 1\text{ V to } -1.5\text{ V}$, $R_L = 2\text{ k}\Omega$ | 25°C | | 50 | 220 | | 50 | 220 | V/mV | |
| | | Full range | | 10 | | | 10 | | | |
| r_i Input resistance | | 25°C | | 70 | | 70 | | M Ω | | |
| c_i Input capacitance | | 25°C | | 2.5 | | 2.5 | | pF | | |
| z_o Open-loop output impedance | $f = 1\text{ MHz}$ | 25°C | | 30 | | 30 | | Ω | | |
| CMRR Common-mode rejection ratio | $V_{IC} = V_{ICRmin}$, $R_S = 50\ \Omega$ | 25°C | | 85 | 118 | | 85 | 118 | dB | |
| | | Full range | | 80 | | | 80 | | | |
| k_{SVR} Supply-voltage rejection ratio ($\Delta V_{CC\pm} / \Delta V_{IO}$) | $V_{CC\pm} = \pm 2.5\text{ V to } \pm 15\text{ V}$, $R_S = 50\ \Omega$ | 25°C | | 90 | 106 | | 90 | 106 | dB | |
| | | Full range | | 85 | | | 85 | | | |
| I_{CC} Supply current | $V_O = 2.5\text{ V}$, $V_{IC} = 2.5\text{ V}$, No load, | 25°C | | 6.6 | 8.8 | | 6.6 | 8.8 | mA | |
| | | Full range | | | 9.2 | | | 9.2 | | |

† Full range is -40°C to 105°C.



TLE2142, TLE2142A, TLE2142Y
EXCALIBUR LOW-NOISE HIGH-SPEED
PRECISION DUAL OPERATIONAL AMPLIFIERS
 SLOS064B – DECEMBER 1990 – REVISED AUGUST 1994

operating characteristics, $V_{CC} = 5\text{ V}$, $T_A = 25^\circ\text{C}$

| PARAMETER | | TEST CONDITIONS | | TLE2142I | | | TLE2142AI | | | UNIT |
|-------------|---|--|--|---|-----|---------|-----------|-----|------------------------|------|
| | | | | MIN | TYP | MAX | MIN | TYP | MAX | |
| SR+ | Positive slew rate | $A_{VD} = -1$, $C_L = 500\text{ pF}$ | | $R_L = 2\text{ k}\Omega^\dagger$ | | 45 | | | V/ μs | |
| SR- | Negative slew rate | | | | | 42 | | | | |
| t_s | Settling time | $A_{VD} = -1$, 2.5-V step | | To 0.1% | | 0.16 | | | μs | |
| | | | | To 0.01% | | 0.22 | | | | |
| V_n | Equivalent input noise voltage | $R_S = 20\ \Omega$, $f = 10\text{ Hz}$ | | | | 15 | | | nV/ $\sqrt{\text{Hz}}$ | |
| | | $R_S = 20\ \Omega$, $f = 1\text{ kHz}$ | | | | 10.5 | | | | |
| $V_{N(PP)}$ | Peak-to-peak equivalent input noise voltage | $f = 0.1\text{ Hz to }1\text{ Hz}$ | | | | 0.48 | | | μV | |
| | | $f = 0.1\text{ Hz to }10\text{ Hz}$ | | | | 0.51 | | | | |
| I_n | Equivalent input noise current | $f = 10\text{ Hz}$ | | | | 1.92 | | | pA/ $\sqrt{\text{Hz}}$ | |
| | | $f = 1\text{ kHz}$ | | | | 0.5 | | | | |
| THD + N | Total harmonic distortion plus noise | $V_O = 1\text{ V to }3\text{ V}$, $A_{VD} = 2$ | | $R_L = 2\text{ k}\Omega^\dagger$, $f = 10\text{ kHz}$ | | 0.0052% | | | | |
| B_1 | Unity-gain bandwidth | $R_L = 2\text{ k}\Omega^\dagger$, $C_L = 100\text{ pF}$ | | | | 5.9 | | | MHz | |
| | Gain-bandwidth product | $R_L = 2\text{ k}\Omega^\dagger$, $f = 100\text{ kHz}$ | | | | 5.8 | | | MHz | |
| B_{OM} | Maximum output-swing bandwidth | $V_{O(PP)} = 2\text{ V}$, $A_{VD} = 1$ | | $R_L = 2\text{ k}\Omega^\dagger$, $C_L = 100\text{ pF}$ | | 660 | | | kHz | |
| ϕ_m | Phase margin at unity gain | $R_L = 2\text{ k}\Omega^\dagger$, $C_L = 100\text{ pF}$ | | | | 57° | | | | |

$^\dagger R_L$ terminates at 2.5 V.

TLE2142, TLE2142A, TLE2142Y
EXCALIBUR LOW-NOISE HIGH-SPEED
PRECISION DUAL OPERATIONAL AMPLIFIERS

SLOS064B – DECEMBER 1990 – REVISED AUGUST 1994

electrical characteristics at specified free-air temperature, $V_{CC\pm} = \pm 15$ V (unless otherwise noted)

| PARAMETER | TEST CONDITIONS | T_A † | TLE2142I | | | TLE2142I | | | UNIT |
|---|--|------------|-----------------|---------------|------|-------------|---------------|------------|------|
| | | | MIN | TYP | MAX | MIN | TYP | MAX | |
| V_{IO} Input offset voltage | $V_{IC} = 0, R_S = 50 \Omega, V_O = 0$ | 25°C | 290 | 1200 | | 275 | 750 | μ V | |
| | | Full range | | 1800 | | 1400 | | | |
| α_{VIO} Temperature coefficient of input offset voltage | | Full range | 1.7 | | | 1.7 | | μ V/°C | |
| I_{IO} Input offset current | | 25°C | 7 | 100 | | 7 | 100 | nA | |
| | | Full range | | 200 | | 200 | | | |
| I_{IB} Input bias current | | 25°C | -0.7 | -1.5 | | -0.7 | -1.5 | μ A | |
| | Full range | | -1.7 | | -1.7 | | | | |
| V_{ICR} Common-mode input voltage range | $R_S = 50 \Omega$ | 25°C | -15 to 13 | -15.3 to 13.2 | | -15 to 13 | -15.3 to 13.2 | V | |
| | | Full range | -15 to 12.7 | -15.3 to 12.9 | | -15 to 12.7 | -15.3 to 12.9 | | |
| V_{OM+} Maximum positive peak output voltage swing | $I_O = -150 \mu$ A | 25°C | 13.8 | 14.1 | | 13.8 | 14.1 | V | |
| | $I_O = -1.5$ mA | | 13.7 | 14 | | 13.7 | 14 | | |
| | $I_O = -15$ mA | | 13.3 | 13.7 | | 13.3 | 13.7 | | |
| | $I_O = -100 \mu$ A | Full range | 13.7 | | | 13.7 | | | |
| | $I_O = -1$ mA | | 13.6 | | | 13.6 | | | |
| | $I_O = -10$ mA | | 13.3 | | | 13.3 | | | |
| V_{OM-} Maximum negative peak output voltage swing | $I_O = 150 \mu$ A | 25°C | -14.7 | -14.9 | | -14.7 | -14.9 | V | |
| | $I_O = 1.5$ mA | | -14.5 | -14.8 | | -14.5 | -14.8 | | |
| | $I_O = 15$ mA | | -13.4 | -13.8 | | -13.4 | -13.8 | | |
| | $I_O = 100 \mu$ A | Full range | -14.6 | | | -14.6 | | | |
| | $I_O = 1$ mA | | -14.5 | | | -14.5 | | | |
| | $I_O = 10$ mA | | -13.4 | | | -13.4 | | | |
| A_{VD} Large-signal differential voltage amplification | $V_O = \pm 10$ V, $R_L = 2$ k Ω | 25°C | 100 | 450 | | 100 | 450 | V/mV | |
| | | Full range | 40 | | | 40 | | | |
| r_i Input resistance | | 25°C | 65 | | | 65 | M Ω | | |
| c_i Input capacitance | | 25°C | 2.5 | | | 2.5 | pF | | |
| z_o Open-loop output impedance | $f = 1$ MHz | 25°C | 30 | | | 30 | Ω | | |
| CMRR Common-mode rejection ratio | $V_{IC} = V_{ICRmin}$ | 25°C | 85 | 108 | | 85 | 108 | dB | |
| | $R_S = 50 \Omega$ | Full range | 80 | | | 80 | | | |
| k_{SVR} Supply-voltage rejection ratio ($\Delta V_{CC\pm} / \Delta V_{IO}$) | $V_{CC\pm} = \pm 2.5$ V to ± 15 V, $R_S = 50 \Omega$ | 25°C | 90 | 106 | | 90 | 106 | dB | |
| | | Full range | 85 | | | 85 | | | |
| I_{OS} Short-circuit output current | $V_O = 0$ | 25°C | $V_{ID} = 1$ V | -25 | -50 | | -25 | -50 | mA |
| | | | $V_{ID} = -1$ V | 20 | 31 | | 20 | 31 | |
| I_{CC} Supply current | $V_O = 0, \text{ No load}$ | 25°C | 6.9 | 9 | | 6.9 | 9 | mA | |
| | | Full range | | 9.4 | | | 9.4 | | |

† Full range is -40°C to 105°C.



TLE2142, TLE2142A, TLE2142Y
EXCALIBUR LOW-NOISE HIGH-SPEED
PRECISION DUAL OPERATIONAL AMPLIFIERS
 SLOS064B – DECEMBER 1990 – REVISED AUGUST 1994

operating characteristics, $V_{CC\pm} = \pm 15\text{ V}$, $T_A = 25^\circ\text{C}$

| PARAMETER | TEST CONDITIONS | TLE2142I | | | TLE2142AI | | | UNIT | |
|-------------|---|--|---|--------------------------|-----------|------|------------------------|---------------|------------------|
| | | MIN | TYP | MAX | MIN | TYP | MAX | | |
| SR+ | Positive slew rate | $A_{VD} = -1$, $C_L = 500\text{ pF}$ | | $R_L = 2\text{ k}\Omega$ | 30 | 45 | 30 | 45 | V/ μs |
| SR- | Negative slew rate | | | | 30 | 42 | 30 | 42 | |
| t_s | Settling time | $A_{VD} = -1$, 10-V step | To 0.1% | 0.34 | | | 0.34 | μs | |
| | | | To 0.01% | 0.4 | | | 0.4 | | |
| V_n | Equivalent input noise voltage | $R_S = 20\ \Omega$, $f = 10\text{ Hz}$ | 15 | | | 15 | nV/ $\sqrt{\text{Hz}}$ | | |
| | | $R_S = 20\ \Omega$, $f = 1\text{ kHz}$ | 10.5 | | | 10.5 | | | |
| $V_{N(PP)}$ | Peak-to-peak equivalent input noise voltage | $f = 0.1\text{ Hz to }1\text{ Hz}$ | 0.48 | | | 0.48 | μV | | |
| | | $f = 0.1\text{ Hz to }10\text{ Hz}$ | 0.51 | | | 0.51 | | | |
| I_n | Equivalent input noise current | $f = 10\text{ Hz}$ | 1.89 | | | 1.89 | pA/ $\sqrt{\text{Hz}}$ | | |
| | | $f = 1\text{ kHz}$ | 0.47 | | | 0.47 | | | |
| THD + N | Total harmonic distortion plus noise | $V_{O(PP)} = 20\text{ V}$, $A_{VD} = 10$, | $R_L = 2\text{ k}\Omega$, $f = 10\text{ kHz}$ | 0.01% | | | 0.01% | | |
| B_1 | Unity-gain bandwidth | $R_L = 2\text{ k}\Omega$, | $C_L = 100\text{ pF}$ | 6 | | | 6 | MHz | |
| | Gain-bandwidth product | $R_L = 2\text{ k}\Omega$, $f = 100\text{ kHz}$ | $C_L = 100\text{ pF}$, | 5.9 | | | 5.9 | MHz | |
| BOM | Maximum output-swing bandwidth | $V_{O(PP)} = 20\text{ V}$, $A_{VD} = 1$, | $R_L = 2\text{ k}\Omega$, $C_L = 100\text{ pF}$ | 668 | | | 668 | kHz | |
| ϕ_m | Phase margin at unity gain | $R_L = 2\text{ k}\Omega$, | $C_L = 100\text{ pF}$ | 58° | | | 58° | | |

TLE2142, TLE2142A, TLE2142Y
EXCALIBUR LOW-NOISE HIGH-SPEED
PRECISION DUAL OPERATIONAL AMPLIFIERS

SLOS064B – DECEMBER 1990 – REVISED AUGUST 1994

electrical characteristics at specified free-air temperature, $V_{CC} = 5\text{ V}$ (unless otherwise noted)

| PARAMETER | TEST CONDITIONS | T_A † | TLE2142M | | | TLE2142AM | | | UNIT |
|---|---|------------|----------|-------------|------|-----------|------------------|------|------------------------------|
| | | | MIN | TYP | MAX | MIN | TYP | MAX | |
| V_{IO} Input offset voltage | $V_O = 2.5\text{ V}$, $V_{IC} = 2.5\text{ V}$ $R_S = 50\ \Omega$ | 25°C | | 220 | 1900 | | 200 | 1500 | μV |
| | | Full range | | | 2600 | | | 2200 | |
| α_{VIO} Temperature coefficient of input offset voltage | | Full range | | 1.7 | | | 1.7 | | $\mu\text{V}/^\circ\text{C}$ |
| I_{IO} Input offset current | | 25°C | | 8 | 100 | | 8 | 100 | nA |
| | | Full range | | | 200 | | | 200 | |
| I_{IB} Input bias current | | 25°C | | -0.8 | -2 | | -0.8 | -2 | μA |
| | Full range | | | -2.3 | | | -2.3 | | |
| V_{ICR} Common-mode input voltage range | $R_S = 50\ \Omega$ | 25°C | 0 to 3 | -0.3 to 3.2 | | 0 to 3 | -0.3 to 3.2 | V | |
| | | Full range | 0 to 2.7 | -0.3 to 2.9 | | 0 to 2.7 | -0.3 to 2.9 | | |
| V_{OH} High-level output voltage | $I_{OH} = -150\ \mu\text{A}$ $I_{OH} = -1.5\text{ mA}$ $I_{OH} = -15\text{ mA}$ $I_{OH} = 100\ \mu\text{A}$ $I_{OH} = 1\text{ mA}$ $I_{OH} = 10\text{ mA}$ | 25°C | | 3.9 | 4.1 | | 3.9 | 4.1 | V |
| | | | | 3.8 | 4 | | 3.8 | 4 | |
| | | | | 3.4 | 3.7 | | 3.4 | 3.7 | |
| | | Full range | | 3.75 | | | 3.75 | | |
| | | | | 3.65 | | | 3.65 | | |
| | | | | 3.45 | | | 3.45 | | |
| V_{OL} Low-level output voltage | $I_{OL} = 150\ \mu\text{A}$ $I_{OL} = 1.5\text{ mA}$ $I_{OL} = 15\text{ mA}$ $I_{OL} = 100\ \mu\text{A}$ $I_{OL} = 1\text{ mA}$ $I_{OL} = 10\text{ mA}$ | 25°C | | 75 | 125 | | 75 | 125 | mV |
| | | | | 150 | 225 | | 150 | 225 | |
| | | | | 1.2 | 1.4 | | 1.2 | 1.4 | |
| | | Full range | | | 200 | | | 200 | mV |
| | | | | | 250 | | | 250 | |
| | | | | | 1.25 | | | 1.25 | V |
| A_{VD} Large-signal differential voltage amplification | $V_{IC} = \pm 2.5\text{ V}$, $R_L = 2\text{ k}\Omega$, $V_O = 1\text{ V to } -1.5\text{ V}$ | 25°C | 50 | 220 | | 50 | 220 | V/mV | |
| | | Full range | 5 | | | 5 | | | |
| r_i Input resistance | | 25°C | | 70 | | 70 | $\text{M}\Omega$ | | |
| c_i Input capacitance | | 25°C | | 2.5 | | 2.5 | pF | | |
| z_o Open-loop output impedance | $f = 1\text{ MHz}$ | 25°C | | 30 | | 30 | Ω | | |
| CMRR Common-mode rejection ratio | $V_{IC} = V_{ICRmin}$, $R_S = 50\ \Omega$ | 25°C | 85 | 118 | | 85 | 118 | dB | |
| | | Full range | 80 | | | 80 | | | |
| k_{SVR} Supply-voltage rejection ratio ($\Delta V_{CC\pm} / \Delta V_{IO}$) | $V_{CC\pm} = \pm 2.5\text{ V to } \pm 15\text{ V}$, $R_S = 50\ \Omega$ | 25°C | 90 | 106 | | 90 | 106 | dB | |
| | | Full range | 85 | | | 85 | | | |
| I_{CC} Supply current | $V_O = 2.5\text{ V}$, $V_{IC} = 2.5\text{ V}$ No load, | 25°C | | 6.6 | 8.8 | | 6.6 | 8.8 | mA |
| | | Full range | | | 9.2 | | | 9.2 | |

† Full range is -55°C to 125°C.



TLE2142, TLE2142A, TLE2142Y
EXCALIBUR LOW-NOISE HIGH-SPEED
PRECISION DUAL OPERATIONAL AMPLIFIERS
 SLOS064B – DECEMBER 1990 – REVISED AUGUST 1994

operating characteristics, $V_{CC} = 5\text{ V}$, $T_A = 25^\circ\text{C}$

| PARAMETER | TEST CONDITIONS | TLE2142M | | | TLE2142AM | | | UNIT |
|-------------|---|--|---|----------------------------------|-----------|------------------------|---------------|------------------|
| | | MIN | TYP | MAX | MIN | TYP | MAX | |
| SR+ | Positive slew rate | $A_{VD} = -1$, $C_L = 500\text{ pF}$ | | $R_L = 2\text{ k}\Omega^\dagger$ | 45 | | | V/ μs |
| SR- | Negative slew rate | | | | 42 | | | |
| t_s | Settling time | $A_{VD} = -1$, 2.5-V step | To 0.1% | 0.16 | | | μs | |
| | | | To 0.01% | 0.22 | | | | |
| V_n | Equivalent input noise voltage | $R_S = 20\ \Omega$, $f = 10\text{ Hz}$ | 15 | | | nV/ $\sqrt{\text{Hz}}$ | | |
| | | $R_S = 20\ \Omega$, $f = 1\text{ kHz}$ | 10.5 | | | | | |
| $V_{N(PP)}$ | Peak-to-peak equivalent input noise voltage | $f = 0.1\text{ Hz to }1\text{ Hz}$ | 0.48 | | | μV | | |
| | | $f = 0.1\text{ Hz to }10\text{ Hz}$ | 0.51 | | | | | |
| I_n | Equivalent input noise current | $f = 10\text{ Hz}$ | 1.92 | | | pA/ $\sqrt{\text{Hz}}$ | | |
| | | $f = 1\text{ kHz}$ | 0.5 | | | | | |
| THD + N | Total harmonic distortion plus noise | $V_O = 1\text{ V to }3\text{ V}$, $A_{VD} = 2$, | $R_L = 2\text{ k}\Omega^\dagger$, $f = 10\text{ kHz}$ | 0.0052% | | | | |
| B_1 | Unity-gain bandwidth | $R_L = 2\text{ k}\Omega^\dagger$, | $C_L = 100\text{ pF}$ | 5.9 | | | MHz | |
| | Gain-bandwidth product | $R_L = 2\text{ k}\Omega^\dagger$, $f = 100\text{ kHz}$ | $C_L = 100\text{ pF}$ | 5.8 | | | MHz | |
| B_{OM} | Maximum output-swing bandwidth | $V_{O(PP)} = 2\text{ V}$, $A_{VD} = 1$, | $R_L = 2\text{ k}\Omega^\dagger$, $C_L = 100\text{ pF}$ | 660 | | | kHz | |
| ϕ_m | Phase margin | $R_L = 2\text{ k}\Omega^\dagger$, | $C_L = 100\text{ pF}$ | 57° | | | | |

$^\dagger R_L$ terminates at 2.5 V.

TLE2142, TLE2142A, TLE2142Y
EXCALIBUR LOW-NOISE HIGH-SPEED
PRECISION DUAL OPERATIONAL AMPLIFIERS

SLOS064B – DECEMBER 1990 – REVISED AUGUST 1994

electrical characteristics at specified free-air temperature, $V_{CC\pm} = \pm 15$ V (unless otherwise noted)

| PARAMETER | TEST CONDITIONS | T_A † | TLE2142M | | | TLE2142AM | | | UNIT |
|---|--|------------|-----------------|---------------|------|-------------|---------------|------------|------|
| | | | MIN | TYP | MAX | MIN | TYP | MAX | |
| V_{IO} Input offset voltage | $V_{IC} = 0, R_S = 50 \Omega$ | 25°C | 290 | 1200 | | 275 | 750 | μ V | |
| | | Full range | | | 2000 | | 1600 | | |
| α_{VIO} Temperature coefficient of input offset voltage | | Full range | 1.7 | | | 1.7 | | μ V/°C | |
| I_{IO} Input offset current | | 25°C | 7 | 100 | | 7 | 100 | nA | |
| | | Full range | | | 250 | | 250 | | |
| I_{IB} Input bias current | | 25°C | -0.7 | -1.5 | | -0.7 | -1.5 | μ A | |
| | Full range | | | -1.8 | | -1.8 | | | |
| V_{ICR} Common-mode input voltage range | $R_S = 50 \Omega$ | 25°C | -15 to 13 | -15.3 to 13.2 | | -15 to 13 | -15.3 to 13.2 | V | |
| | | Full range | -15 to 12.7 | -15.3 to 12.9 | | -15 to 12.7 | -15.3 to 12.9 | | |
| V_{OM+} Maximum positive peak output voltage swing | $I_O = -150 \mu$ A | 25°C | 13.8 | 14.1 | | 13.8 | 14.1 | V | |
| | $I_O = -1.5$ mA | | 13.7 | 14 | | 13.7 | 14 | | |
| | $I_O = -15$ mA | | 13.3 | 13.7 | | 13.3 | 13.7 | | |
| | $I_O = -100 \mu$ A | Full range | 13.7 | | | 13.7 | | | |
| | $I_O = -1$ mA | | 13.6 | | | 13.6 | | | |
| | $I_O = -10$ mA | | 13.3 | | | 13.3 | | | |
| V_{OM-} Maximum negative peak output voltage swing | $I_O = 150 \mu$ A | 25°C | -14.7 | -14.9 | | -14.7 | -14.9 | V | |
| | $I_O = 1.5$ mA | | -14.5 | -14.8 | | -14.5 | -14.8 | | |
| | $I_O = 15$ mA | | -13.4 | -13.8 | | -13.4 | -13.8 | | |
| | $I_O = 100 \mu$ A | Full range | -14.6 | | | -14.6 | | | |
| | $I_O = 1$ mA | | -14.5 | | | -14.5 | | | |
| | $I_O = 10$ mA | | -13.4 | | | -13.4 | | | |
| A_{VD} Large-signal differential voltage amplification | $V_O = \pm 10$ V, $R_L = 2$ k Ω | 25°C | 100 | 450 | | 100 | 450 | V/mV | |
| | | Full range | 20 | | | 20 | | | |
| r_i Input resistance | | 25°C | 65 | | | 65 | M Ω | | |
| c_i Input capacitance | | 25°C | 2.5 | | | 2.5 | pF | | |
| z_o Open-loop output impedance | $f = 1$ MHz | 25°C | 30 | | | 30 | Ω | | |
| CMRR Common-mode rejection ratio | $V_{IC} = V_{ICRmin}, R_S = 50 \Omega$ | 25°C | 85 | 108 | | 85 | 108 | dB | |
| | | Full range | 80 | | | 80 | | | |
| k_{SVR} Supply-voltage rejection ratio ($\Delta V_{CC\pm} / \Delta V_{IO}$) | $V_{CC\pm} = \pm 2.5$ V to ± 15 V, $R_S = 50 \Omega$ | 25°C | 90 | 106 | | 90 | 106 | dB | |
| | | Full range | 85 | | | 85 | | | |
| I_{OS} Short-circuit output current | $V_O = 0$ | 25°C | $V_{ID} = 1$ V | -25 | -50 | | -25 | -50 | mA |
| | | | $V_{ID} = -1$ V | 20 | 31 | | 20 | 31 | |
| I_{CC} Supply current | $V_O = 0, V_{IC} = 2.5$ V | No load, | 25°C | 6.9 | 9 | | 6.9 | 9 | mA |
| | | | Full range | | | 9.4 | | 9.4 | |

† Full range is -55°C to 125°C.



TLE2142, TLE2142A, TLE2142Y
EXCALIBUR LOW-NOISE HIGH-SPEED
PRECISION DUAL OPERATIONAL AMPLIFIERS
 SLOS064B – DECEMBER 1990 – REVISED AUGUST 1994

operating characteristics, $V_{CC\pm} = \pm 15\text{ V}$, $T_A = 25^\circ\text{C}$

| PARAMETER | | TEST CONDITIONS | | TLE2142M | | | TLE2142AM | | | UNIT |
|-------------|---|--|---|----------|-----|-----|-----------|-----|-----|------------------------|
| | | | | MIN | TYP | MAX | MIN | TYP | MAX | |
| SR+ | Positive slew rate | $R_L = 2\text{ k}\Omega$, $C_L = 100\text{ pF}$ | $A_{VD} = -1$, | 27 | 45 | | 27 | 45 | | V/ μs |
| SR- | Negative slew rate | | | 27 | 42 | | 27 | 42 | | |
| t_s | Settling time | $A_{VD} = -1$, 10-V step | To 0.1% | 0.34 | | | 0.34 | | | μs |
| | | | To 0.01% | 0.4 | | | 0.4 | | | |
| V_n | Equivalent input noise voltage | $R_S = 20\ \Omega$, | $f = 10\text{ Hz}$ | 15 | | | 15 | | | nV/ $\sqrt{\text{Hz}}$ |
| | | | $f = 1\text{ kHz}$ | 10.5 | | | 10.5 | | | |
| $V_{N(PP)}$ | Peak-to-peak equivalent input noise voltage | $f = 0.1\text{ Hz to }1\text{ Hz}$ | | 0.48 | | | 0.48 | | | μV |
| | | $f = 0.1\text{ Hz to }10\text{ Hz}$ | | 0.51 | | | 0.51 | | | |
| I_n | Equivalent input noise current | $f = 10\text{ Hz}$ | | 1.89 | | | 1.89 | | | pA/ $\sqrt{\text{Hz}}$ |
| | | $f = 1\text{ kHz}$ | | 0.47 | | | 0.47 | | | |
| THD + N | Total harmonic distortion plus noise | $V_{O(PP)} = 20\text{ V}$, $R_L = 2\text{ k}\Omega$, $A_{VD} = 10$, $f = 10\text{ kHz}$ | | 0.01% | | | 0.01% | | | |
| B_1 | Unity-gain bandwidth | $R_L = 2\text{ k}\Omega$, | $C_L = 100\text{ pF}$ | 6 | | | 6 | | | MHz |
| | Gain-bandwidth product | $R_L = 2\text{ k}\Omega$, | $C_L = 100\text{ pF}$, $f = 100\text{ kHz}$ | 5.9 | | | 5.9 | | | MHz |
| B_{OM} | Maximum output-swing bandwidth | $V_{O(PP)} = 20\text{ V}$, $R_L = 2\text{ k}\Omega$, $A_{VD} = 1$, $C_L = 100\text{ pF}$ | | 668 | | | 668 | | | kHz |
| ϕ_m | Phase margin at unity gain | $R_L = 2\text{ k}\Omega$, | $C_L = 100\text{ pF}$ | 58° | | | 58° | | | |

TLE2142, TLE2142A, TLE2142Y
EXCALIBUR LOW-NOISE HIGH-SPEED
PRECISION DUAL OPERATIONAL AMPLIFIERS

SLOS064B – DECEMBER 1990 – REVISED AUGUST 1994

electrical characteristics at specified free-air temperature, $V_{CC\pm} = \pm 15\text{ V}$, $T_A = 25^\circ\text{C}$

| PARAMETER | TEST CONDITIONS | TLE2142Y | | | UNIT |
|---|---|-------------------------|---------------------|------|---------------|
| | | MIN | TYP | MAX | |
| V_{IO} Input offset voltage | $V_{IC} = 0$, $V_O = 0$ $R_S = 50\ \Omega$ | | 150 | 875 | μV |
| I_{IO} Input offset current | | | 7 | 100 | nA |
| I_{IB} Input bias current | | | -0.7 | -1.5 | μA |
| V_{ICR} Common-mode input voltage range | $R_S = 50\ \Omega$ | -15 to 13 | -15.3 to 13.2 | | V |
| V_{OM+} Maximum positive peak output voltage swing | $I_O = -150\ \mu\text{A}$ | 13.8 | 14.1 | | V |
| | $I_O = -1.5\ \text{mA}$ | 13.7 | 14 | | |
| | $I_O = -15\ \text{mA}$ | 13.3 | 13.7 | | |
| V_{OM-} Maximum negative peak output voltage swing | $I_O = 150\ \mu\text{A}$ | -14.7 | -14.9 | | V |
| | $I_O = 1.5\ \text{mA}$ | -14.5 | -14.8 | | |
| | $I_O = 15\ \text{mA}$ | -13.4 | -13.8 | | |
| A_{VD} Large-signal differential voltage amplification | $V_O = \pm 10\ \text{V}$, $R_L = 2\ \text{k}\Omega$ | 100 | 450 | | V/mV |
| r_i Input resistance | | | 65 | | M Ω |
| c_i Input capacitance | | | 2.5 | | pF |
| z_o Open-loop output impedance | $f = 1\ \text{MHz}$ | | 30 | | Ω |
| CMRR Common-mode rejection ratio | $V_{IC} = V_{ICRmin}$, $R_S = 50\ \Omega$ | 80 | 108 | | dB |
| k_{SVR} Supply-voltage rejection ratio ($\Delta V_{CC\pm} / \Delta V_{IO}$) | $V_{CC\pm} = \pm 2.5\ \text{V}$ to $\pm 15\ \text{V}$, $R_S = 50\ \Omega$ | 85 | 106 | | dB |
| I_{OS} Short-circuit output current | $V_O = 0$ | $V_{ID} = 1\ \text{V}$ | -25 | -50 | mA |
| | | $V_{ID} = -1\ \text{V}$ | 20 | 31 | |
| I_{CC} Supply current | $V_O = 0$, No load | | 6.9 | 9 | mA |

TYPICAL CHARACTERISTICS

Table of Graphs

| | | FIGURE | |
|-------------|---|------------------------------|----|
| V_{IO} | Input offset voltage | Distribution | 1 |
| I_{IO} | Input offset current | vs Free-air temperature | 2 |
| I_{IB} | Input bias current | vs Free-air temperature | 3 |
| | | vs Common-mode input voltage | 4 |
| V_{OM+} | Maximum positive peak output voltage | vs Supply voltage | 5 |
| | | vs Free-air temperature | 6 |
| | | vs Output current | 7 |
| V_{OM-} | Maximum negative peak output voltage | vs Supply voltage | 5 |
| | | vs Free-air temperature | 6 |
| | | vs Output current | 8 |
| V_{OM} | Maximum peak output voltage | vs Settling time | 9 |
| $V_{O(PP)}$ | Maximum peak-to-peak output voltage | vs Frequency | 10 |
| V_{OH} | High-level output voltage | vs Output current | 11 |
| V_{OL} | Low-level output voltage | vs Output current | 12 |
| A_{VD} | Large-signal differential voltage amplification | vs Free-air temperature | 13 |
| | | vs Frequency | 14 |
| z_o | Closed-loop output impedance | vs Frequency | 15 |
| I_{OS} | Short-circuit output current | vs Free-air temperature | 16 |
| $CMRR$ | Common-mode rejection ratio | vs Frequency | 17 |
| | | vs Free-air temperature | 18 |
| k_{SVR} | Supply voltage rejection ratio | vs Frequency | 19 |
| | | vs Free-air temperature | 20 |
| I_{CC} | Supply current | vs Free-air temperature | 21 |
| | | vs Supply voltage | 22 |
| V_n | Noise voltage | vs Frequency | 23 |
| | | Over a 10-second period | 24 |
| I_n | Equivalent input noise current | vs Frequency | 25 |
| $THD + N$ | Total harmonic distortion plus noise | vs Frequency | 26 |
| SR | Slew rate | vs Free-air temperature | 27 |
| | | vs Load capacitance | 28 |
| | Pulse response | Noninverting large signal | 29 |
| | | Inverting large signal | 30 |
| | | Small signal | 31 |
| B_1 | Unity-gain bandwidth | vs Load capacitance | 32 |
| | Gain margin | vs Load capacitance | 33 |
| ϕ_m | Phase margin | vs Load capacitance | 34 |
| | Phase shift | vs Frequency | 14 |

TYPICAL CHARACTERISTICS†

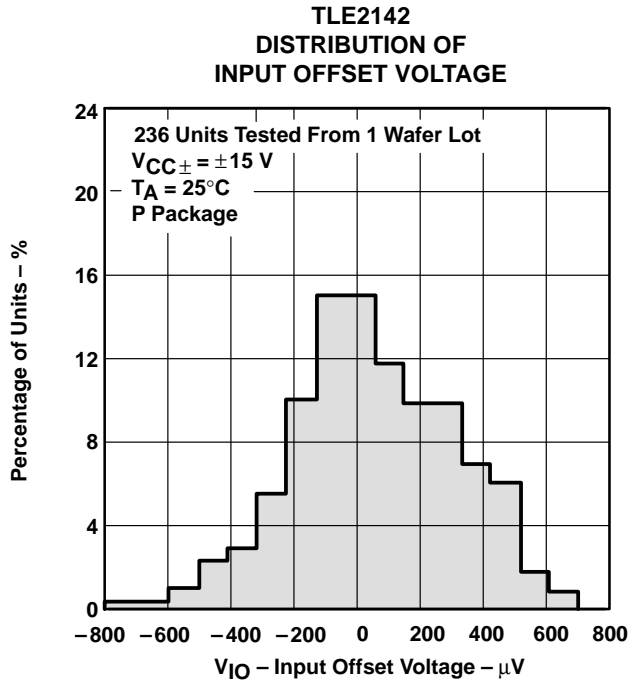

Figure 1

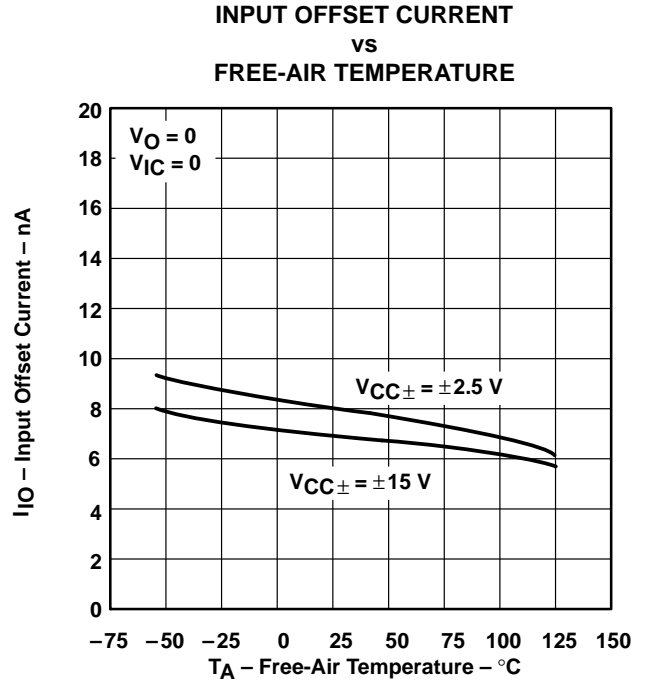

Figure 2

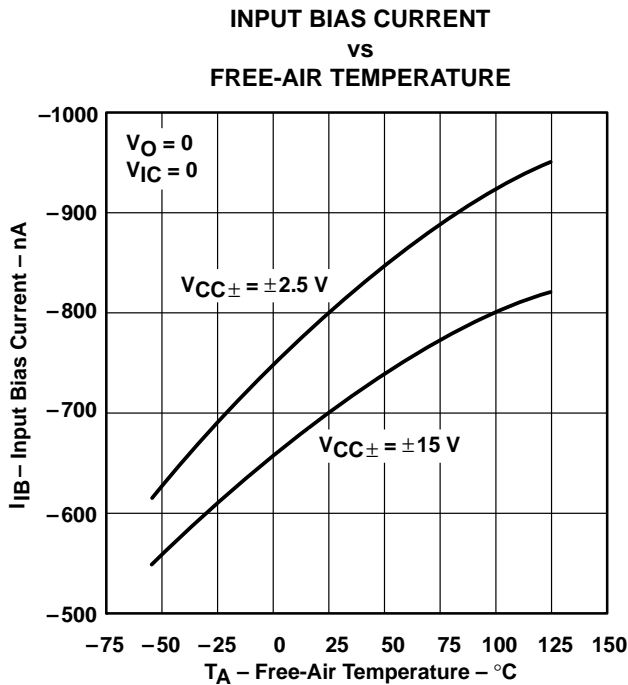

Figure 3

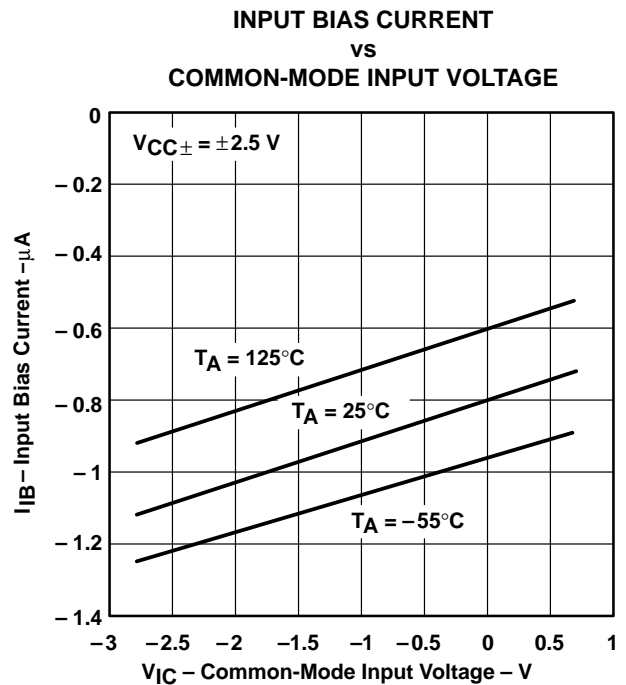

Figure 4

† Data at high and low temperatures are applicable only within the rated operating free-air temperature ranges of the various devices.

TYPICAL CHARACTERISTICS†

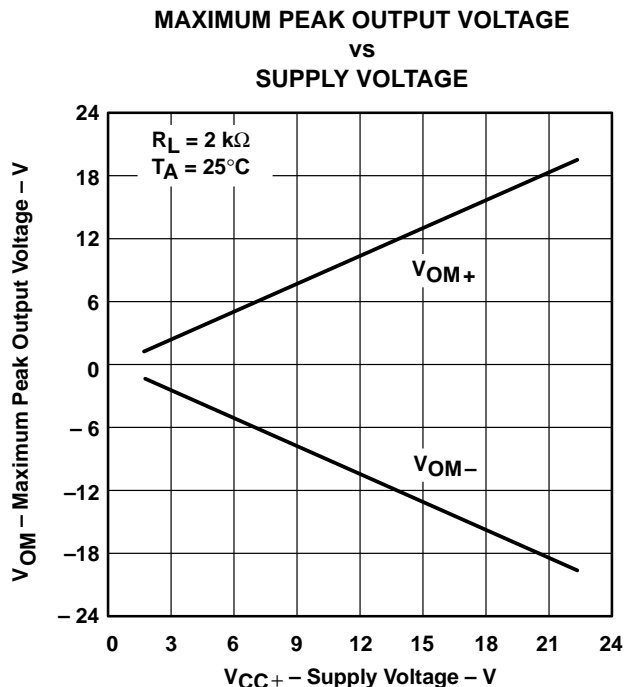

Figure 5

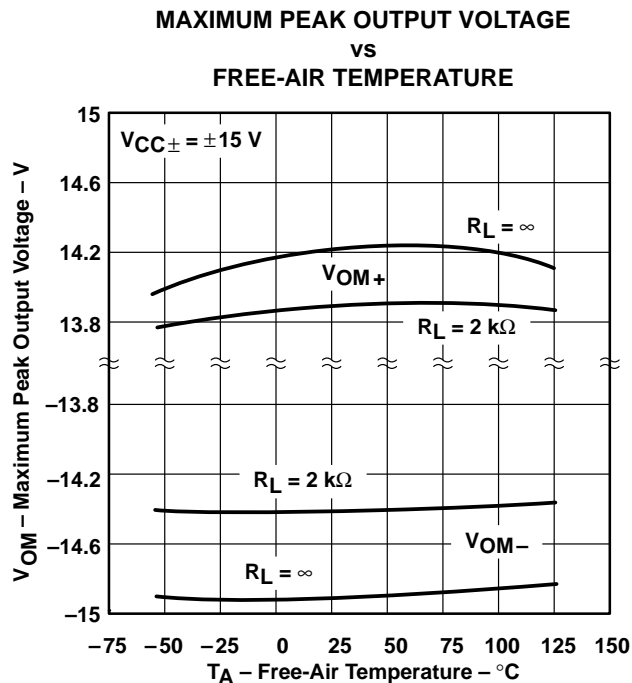

Figure 6

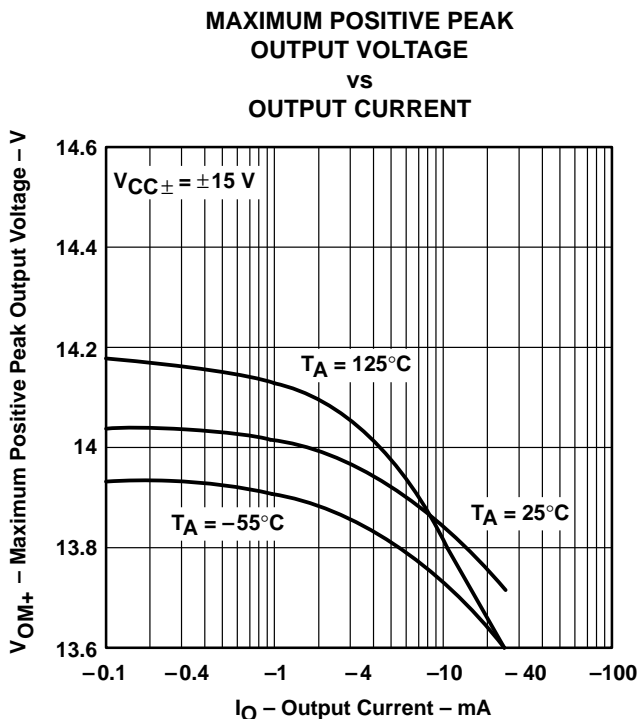

Figure 7

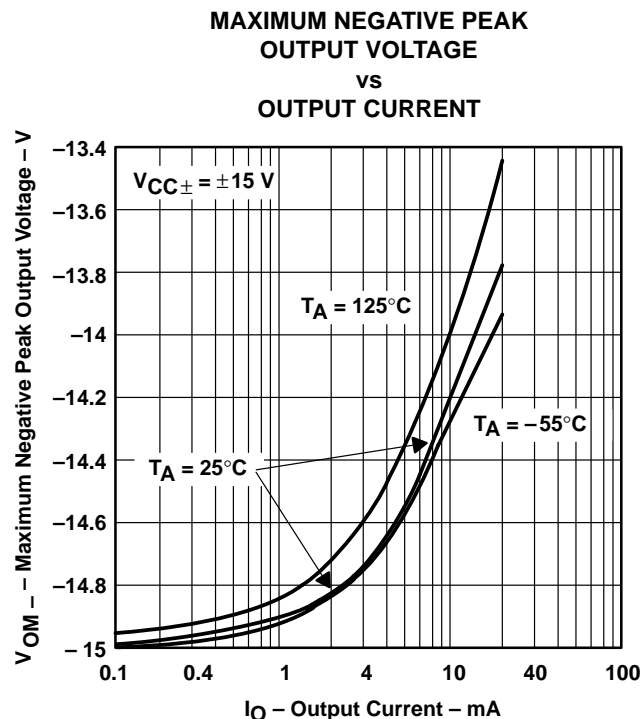
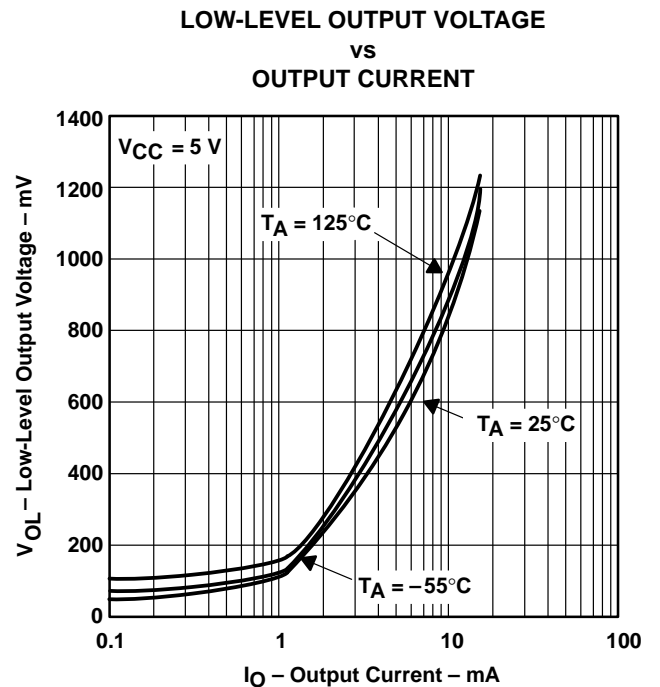
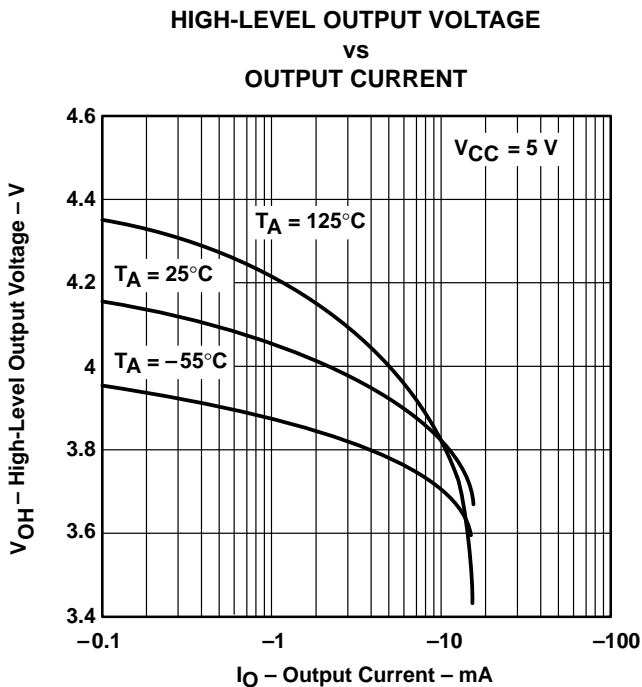
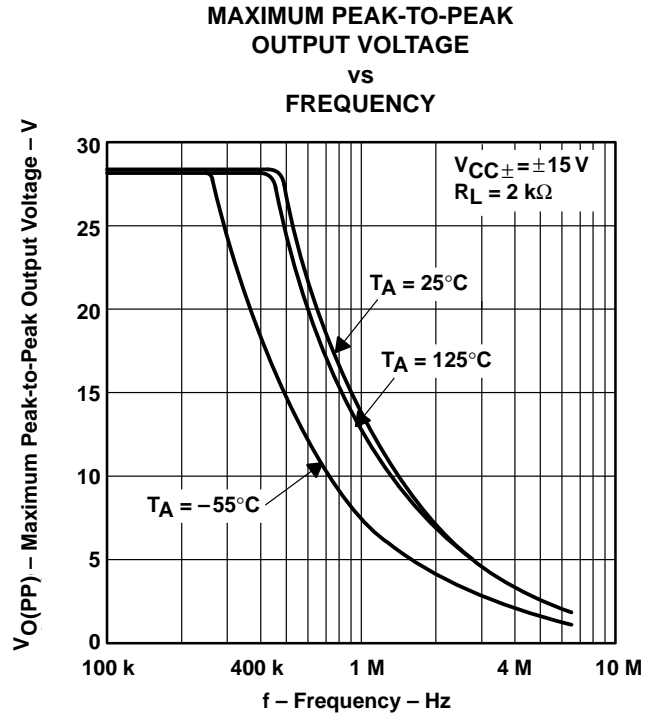
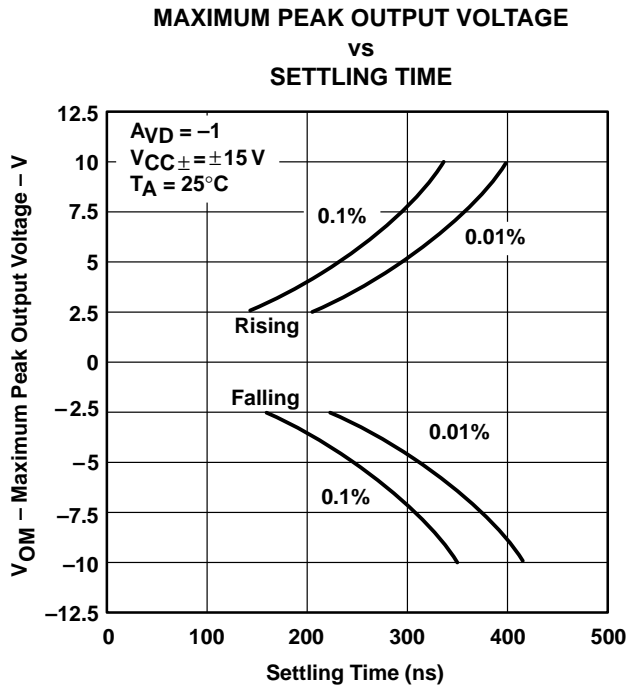

Figure 8

† Data at high and low temperatures are applicable only within the rated operating free-air temperature ranges of the various devices.

TYPICAL CHARACTERISTICS†



† Data at high and low temperatures are applicable only within the rated operating free-air temperature ranges of the various devices.

TYPICAL CHARACTERISTICS†

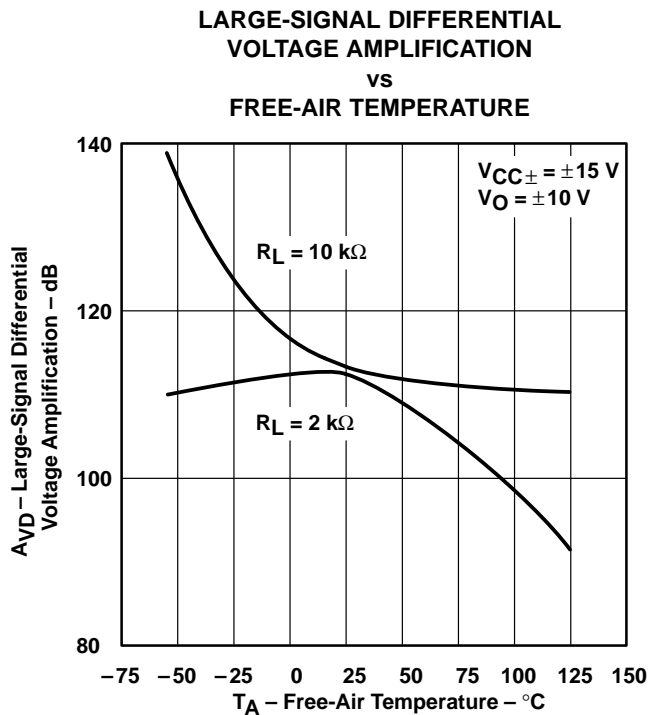

Figure 13

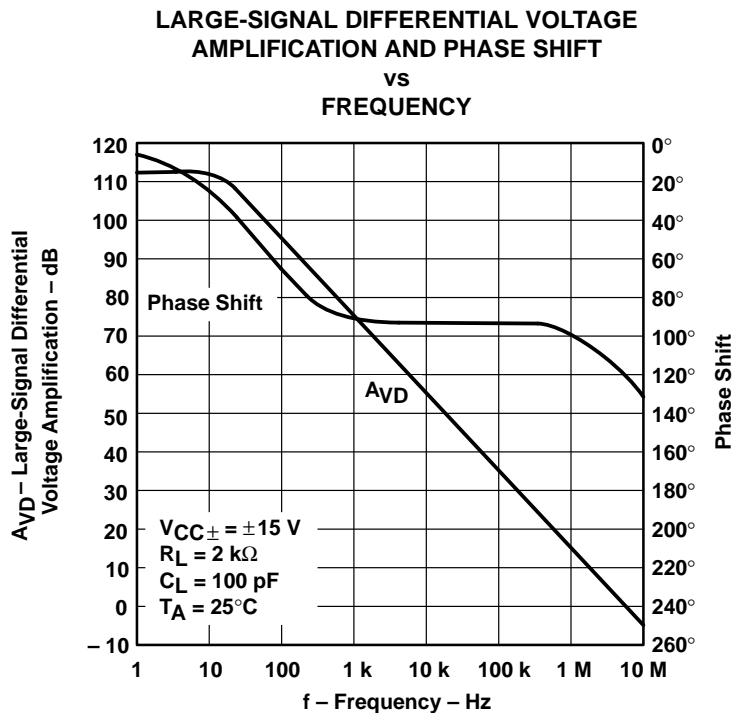
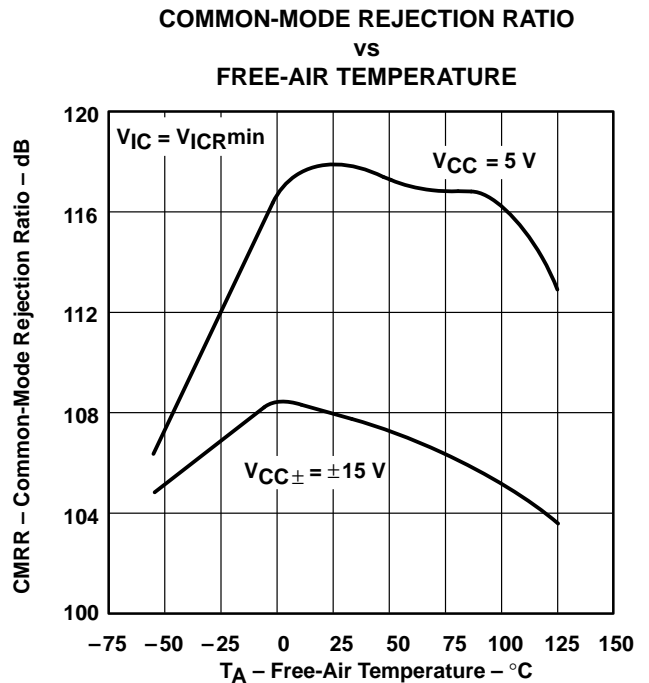
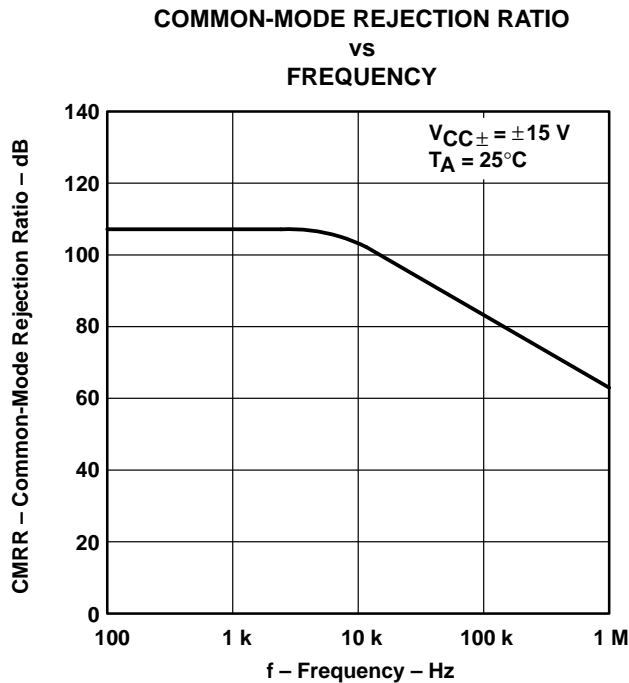
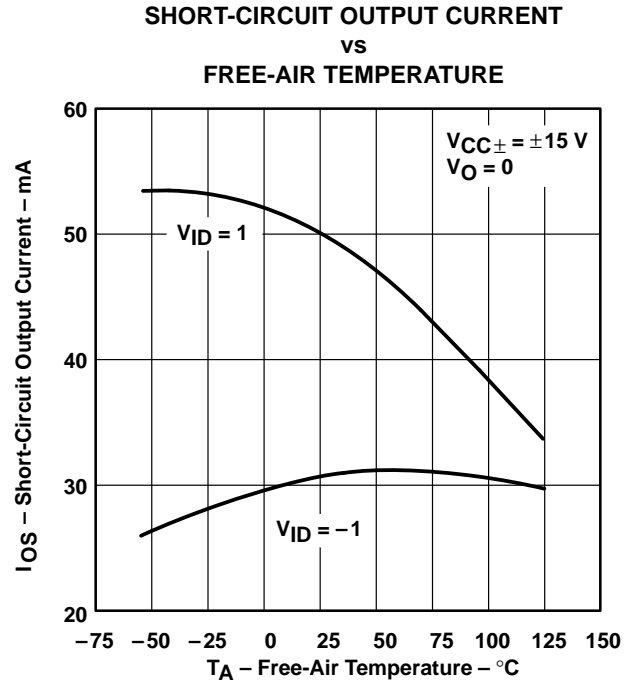
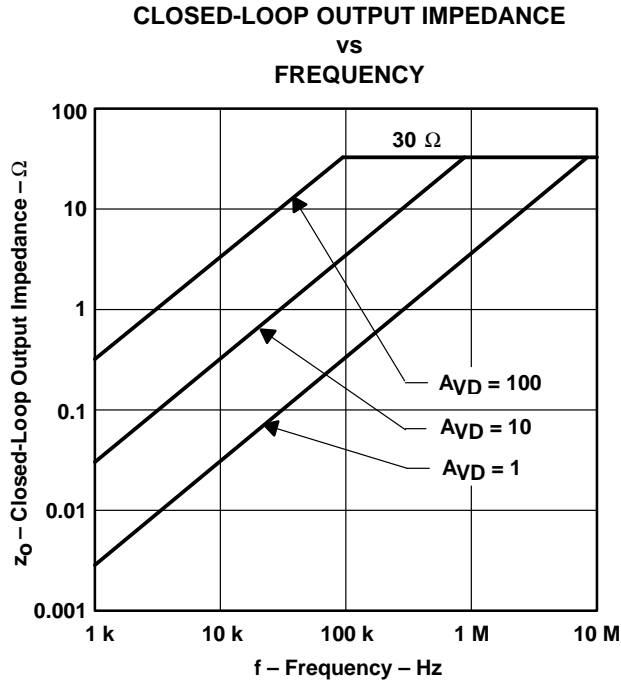

Figure 14

† Data at high and low temperatures are applicable only within the rated operating free-air temperature ranges of the various devices.

TYPICAL CHARACTERISTICS†



† Data at high and low temperatures are applicable only within the rated operating free-air temperature ranges of the various devices.

TYPICAL CHARACTERISTICS†

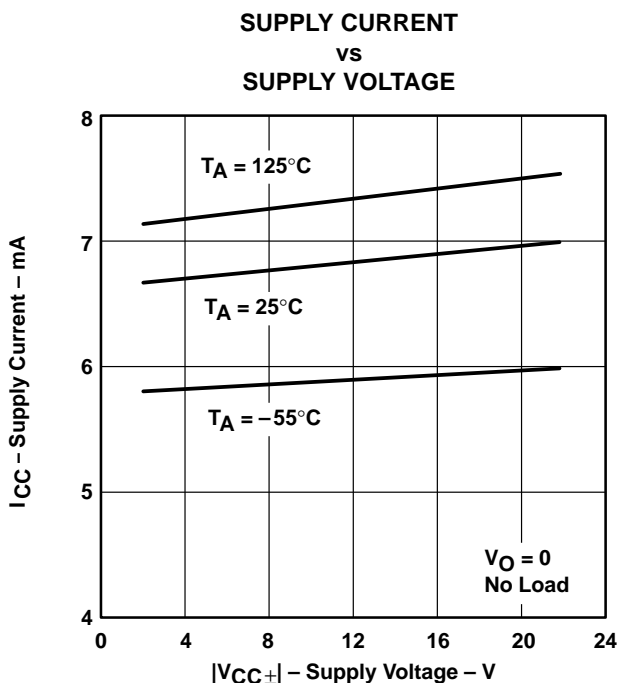
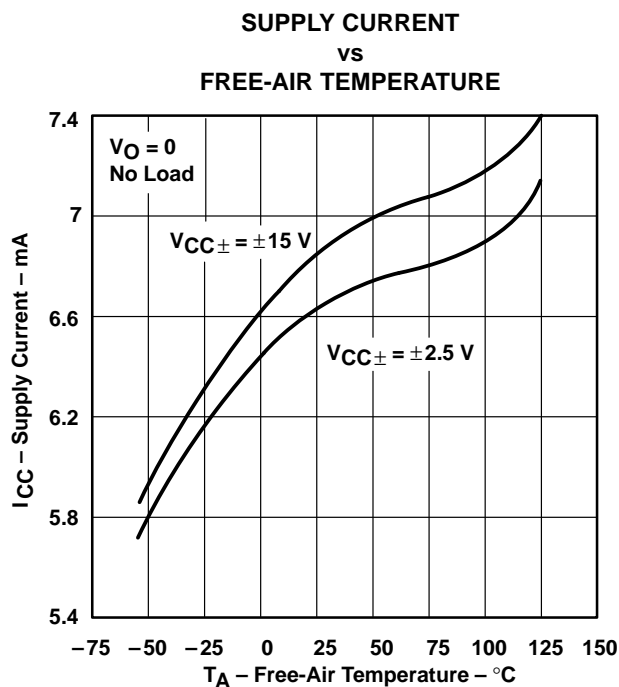
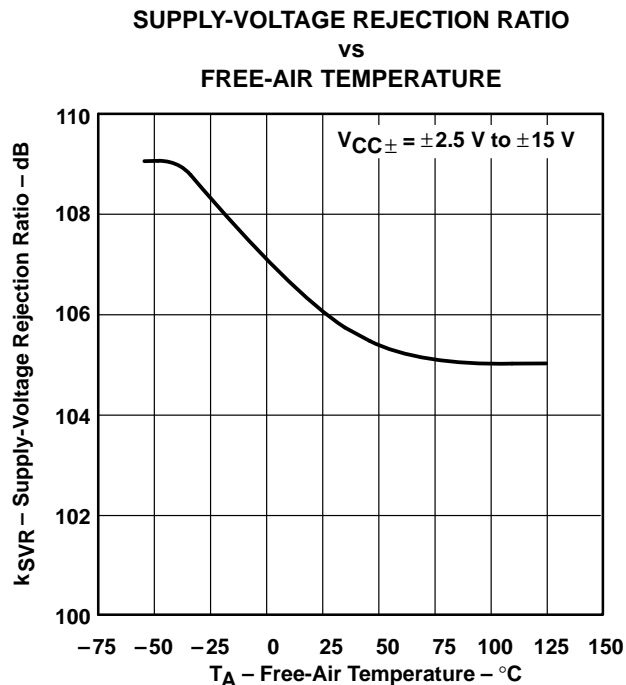
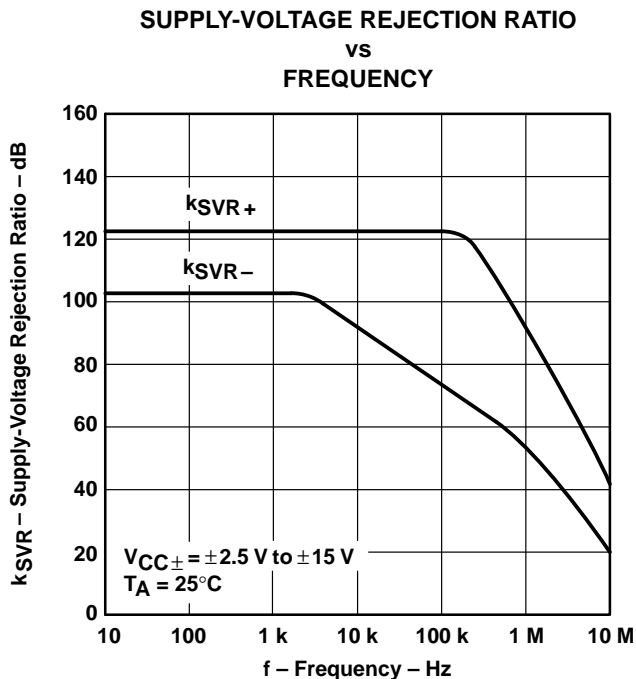

† Data at high and low temperatures are applicable only within the rated operating free-air temperature ranges of the various devices.

TLE2142, TLE2142A, TLE2142Y
 EXCALIBUR LOW-NOISE HIGH-SPEED
 PRECISION DUAL OPERATIONAL AMPLIFIERS

SLOS064B – DECEMBER 1990 – REVISED AUGUST 1994

TYPICAL CHARACTERISTICS†

EQUIVALENT INPUT NOISE VOLTAGE
 vs
 FREQUENCY

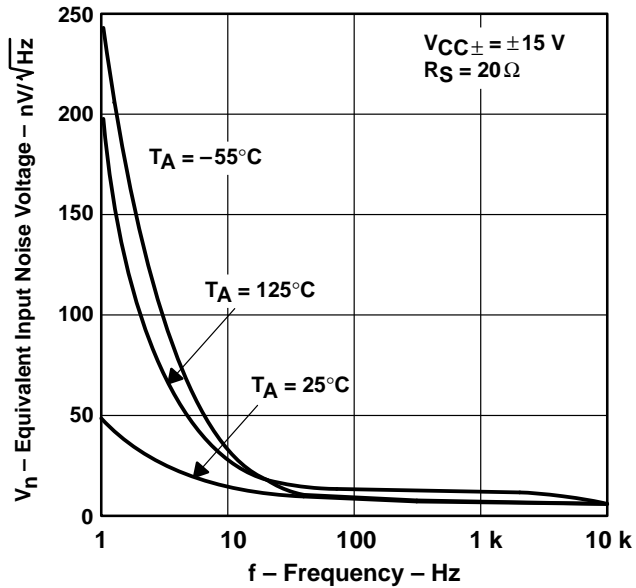

Figure 23

INPUT NOISE VOLTAGE
 OVER A 10-SECOND PERIOD

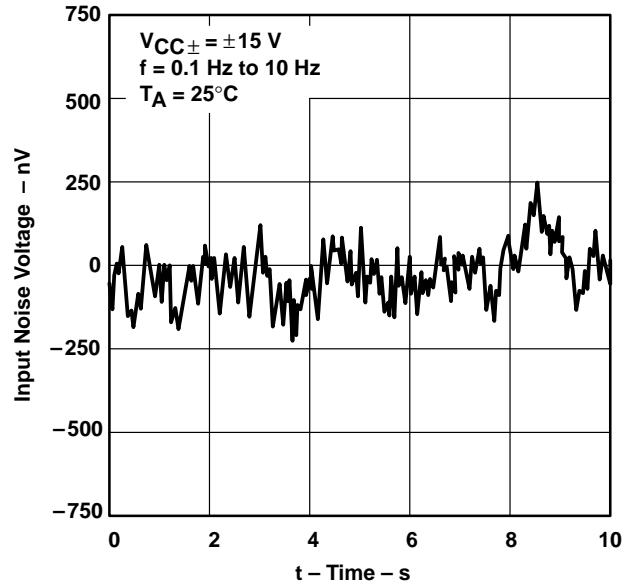

Figure 24

EQUIVALENT INPUT NOISE CURRENT
 vs
 FREQUENCY

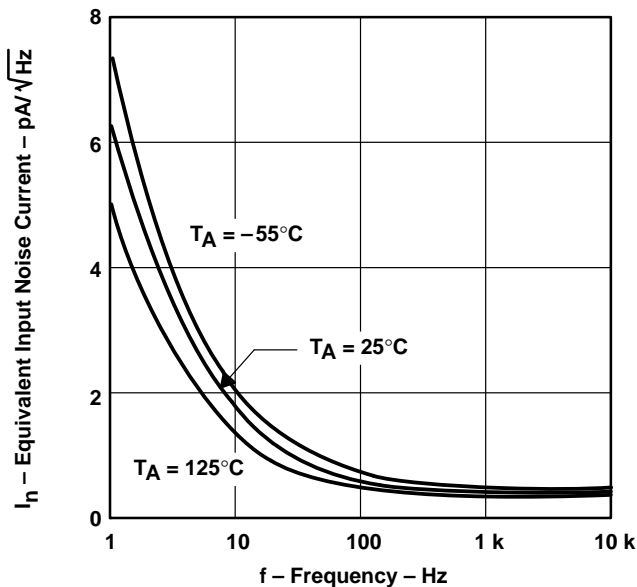

Figure 25

TOTAL HARMONIC DISTORTION + NOISE
 vs
 FREQUENCY

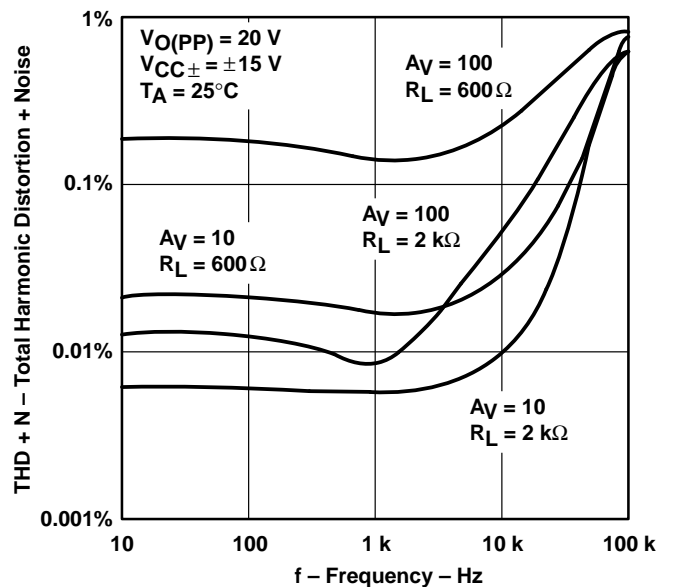
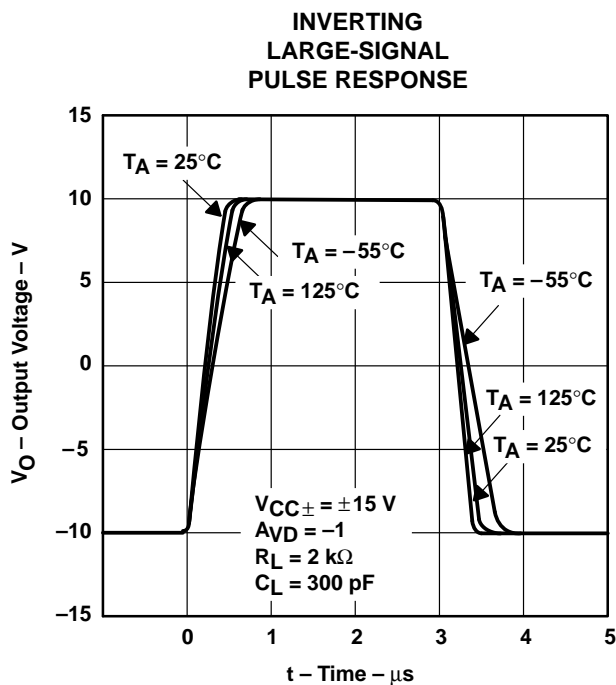
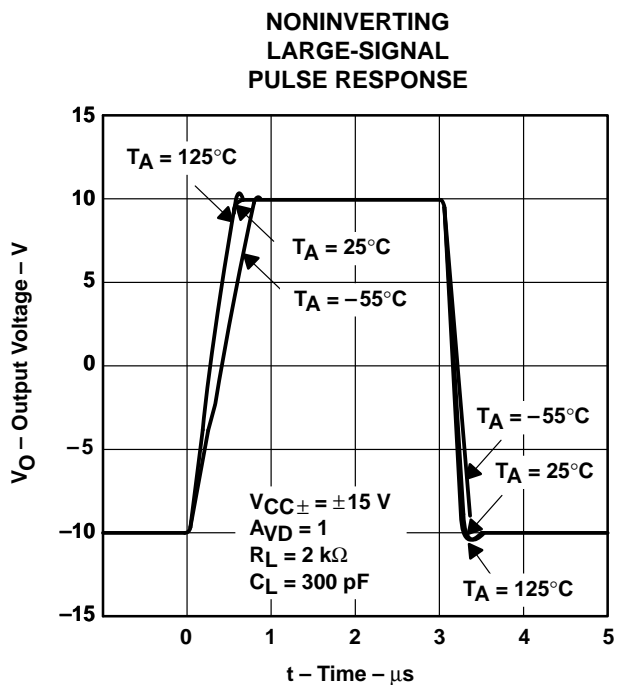
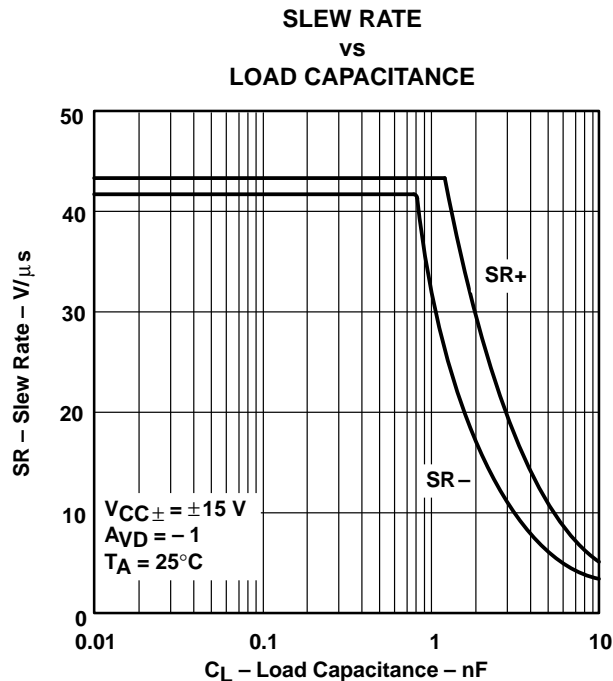
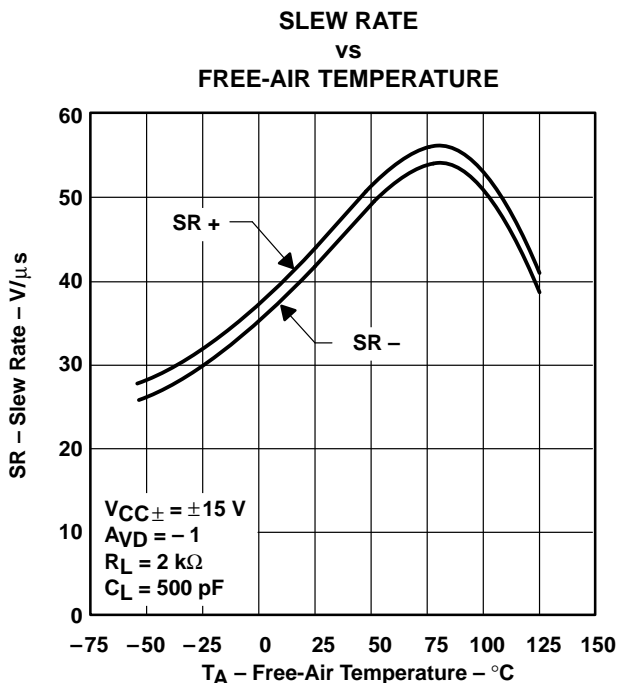

Figure 26

† Data at high and low temperatures are applicable only within the rated operating free-air temperature ranges of the various devices.



TYPICAL CHARACTERISTICS†



† Data at high and low temperatures are applicable only within the rated operating free-air temperature ranges of the various devices.

TYPICAL CHARACTERISTICS†

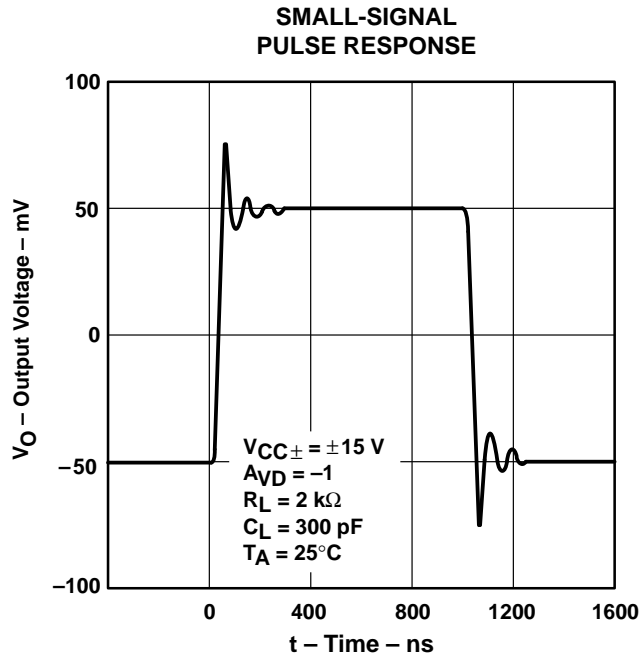

Figure 31

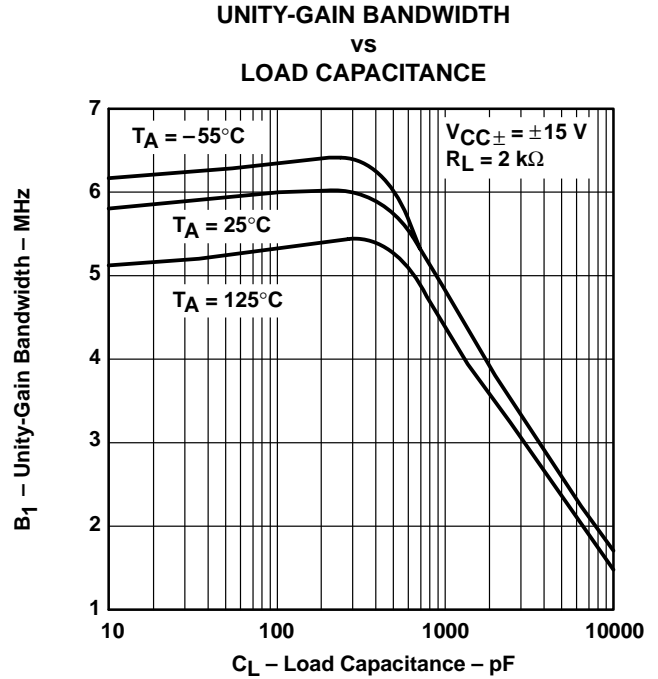

Figure 32

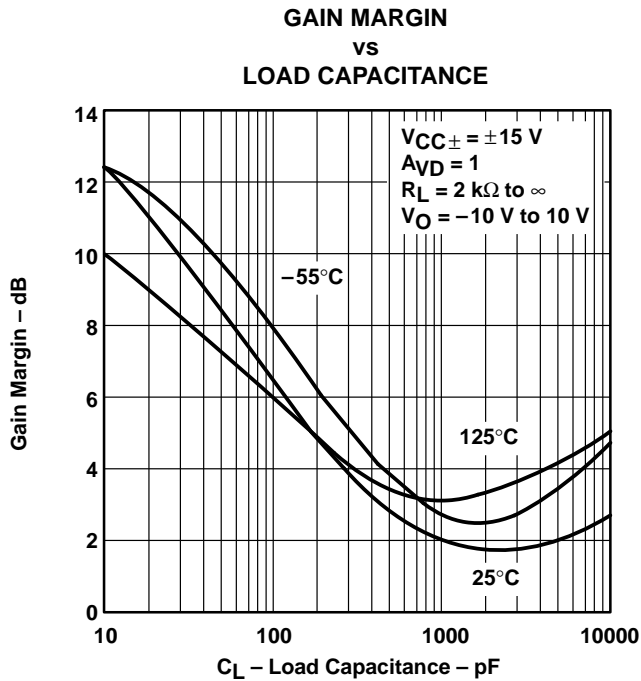

Figure 33

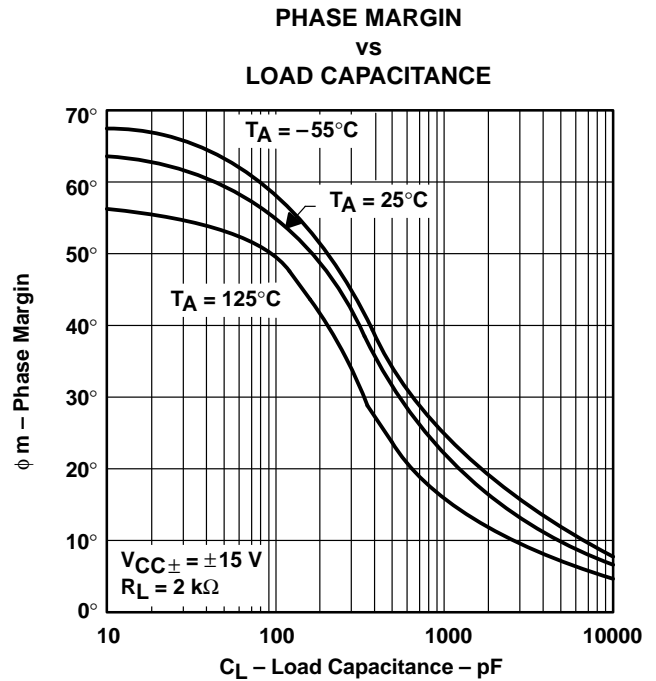

Figure 34

† Data at high and low temperatures are applicable only within the rated operating free-air temperature ranges of the various devices.

IMPORTANT NOTICE

Texas Instruments (TI) reserves the right to make changes to its products or to discontinue any semiconductor product or service without notice, and advises its customers to obtain the latest version of relevant information to verify, before placing orders, that the information being relied on is current.

TI warrants performance of its semiconductor products and related software to the specifications applicable at the time of sale in accordance with TI's standard warranty. Testing and other quality control techniques are utilized to the extent TI deems necessary to support this warranty. Specific testing of all parameters of each device is not necessarily performed, except those mandated by government requirements.

Certain applications using semiconductor products may involve potential risks of death, personal injury, or severe property or environmental damage ("Critical Applications").

TI SEMICONDUCTOR PRODUCTS ARE NOT DESIGNED, INTENDED, AUTHORIZED, OR WARRANTED TO BE SUITABLE FOR USE IN LIFE-SUPPORT APPLICATIONS, DEVICES OR SYSTEMS OR OTHER CRITICAL APPLICATIONS.

Inclusion of TI products in such applications is understood to be fully at the risk of the customer. Use of TI products in such applications requires the written approval of an appropriate TI officer. Questions concerning potential risk applications should be directed to TI through a local SC sales office.

In order to minimize risks associated with the customer's applications, adequate design and operating safeguards should be provided by the customer to minimize inherent or procedural hazards.

TI assumes no liability for applications assistance, customer product design, software performance, or infringement of patents or services described herein. Nor does TI warrant or represent that any license, either express or implied, is granted under any patent right, copyright, mask work right, or other intellectual property right of TI covering or relating to any combination, machine, or process in which such semiconductor products or services might be or are used.