

Smartcard interface

General features

- Designed to be compatible with the NDS conditional access system
- IC card interface
- 3 or 5V supply for the IC (V_{DD} and GND)
- Three specifically protected half-duplex bi-directional buffered I/O lines to card contacts C4, C7 and C8
- DC/DC converter for V_{CC} generation separately powered from a $5\text{ V} \pm 20\%$ supply (V_{DDP} AND PGND)
- 3 or $5\text{ V} \pm 5\%$ regulated card supply voltage (V_{CC}) with appropriate decoupling has the following capabilities:
 - $I_{CC} < 80\text{mA}$ at $V_{DDP} = 4$ to 6.5V
 - Handles current spikes of 40nA up to 20MHz
 - Controls rise and fall times
 - Filtered overload detection at approximately 120mA
- Thermal and short-circuit protection on all card contacts
- Automatic activation and deactivation sequences; initiated by software or by hardware in the event of a short-circuit, card take-off, overheating, V_{DD} or V_{DDP} drop-out
- Enhanced ESD protection on card side ($>6\text{ kV}$)
- 26MHz integrated crystal oscillator
- Clock generation for cards up to 20MHz (divided by 1, 2, 4 or 8 through CLKDIV1 and CLKDIV2 signals) with synchronous frequency changes

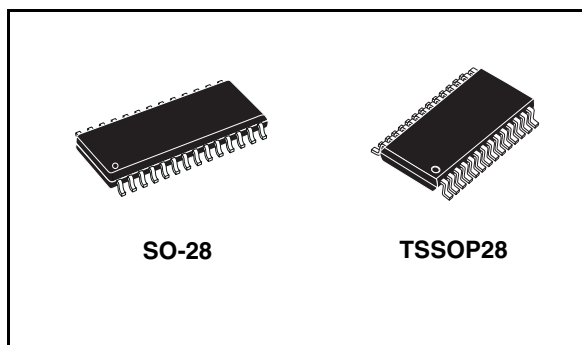

- Non-inverted control of RST via pin RSTIN
- ISO 7816, GSM11.11 and EMV (payment systems) compatibility
- Supply supervisor for spike-killing during power-on and power-off and power-on reset (threshold fixed internally or externally by a resistor bridge)
- Built-in debounce on card presence contacts
- One multiplexed status signal off

Description

The ST8024 is a complete low cost analog interface for asynchronous 3V and 5V smart cards. It can be placed between the card and the microcontroller with few external components to perform all supply protection and control functions. ST8024 is a direct replacement of ST8004.

Main applications are: smartcard readers for Set Top Box, IC card readers for banking, identification, Pay TV.

Order codes

| Part number | Temperature range | Package | Packaging |
|-------------|-------------------|-----------------------|---------------------|
| ST8024CDR | -25 to 85 °C | SO-28 (Tape & Reel) | 1000 parts per reel |
| ST8024CTR | -25 to 85 °C | TSSOP28 (Tape & Reel) | 1000 parts per reel |

Contents

| | | |
|----------|--|-----------|
| 1 | Diagram | 3 |
| 2 | Pin configuration | 4 |
| 3 | Maximum ratings | 6 |
| 4 | Electrical characteristics | 7 |
| 5 | Functional description | 14 |
| 5.1 | Power supply | 14 |
| 5.2 | Voltage supervisor | 14 |
| 5.2.1 | Without external divider on pin PORADJ | 14 |
| 5.2.2 | With an external divider on pin PORADJ | 15 |
| 5.2.3 | Application examples | 15 |
| 5.3 | Clock circuitry | 15 |
| 5.4 | I/O Transceivers | 16 |
| 5.5 | Inactive mode | 17 |
| 5.6 | Activation sequence | 17 |
| 5.7 | Active mode | 19 |
| 5.8 | Deactivation sequence | 19 |
| 5.9 | V _{CC} Generator | 19 |
| 5.10 | Fault detection | 20 |
| 6 | Application | 22 |
| 7 | Package mechanical data | 23 |
| 8 | Revision history | 29 |

1 Diagram

Figure 1. Block diagram

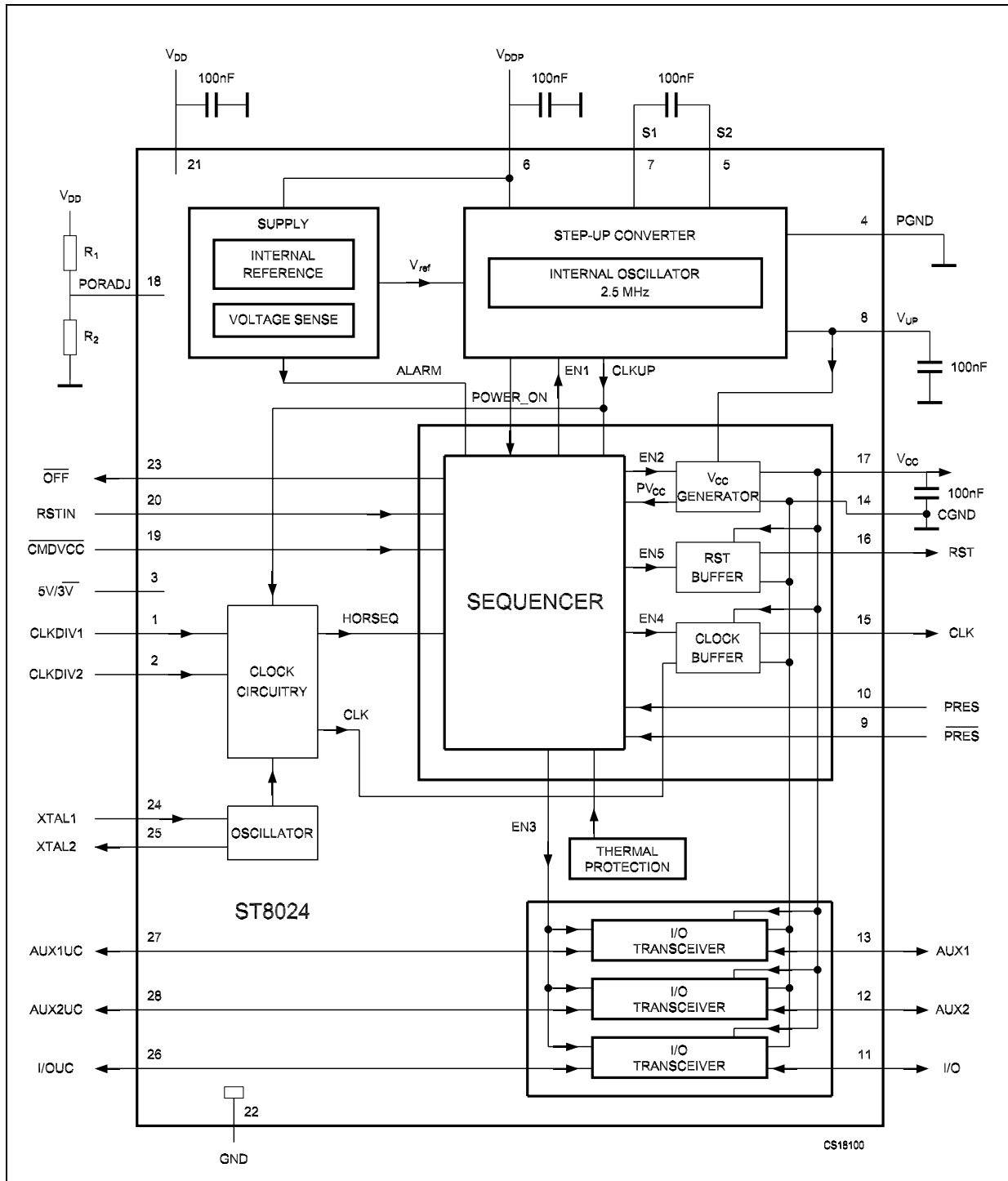

2 Pin configuration

Figure 2. Pin connections

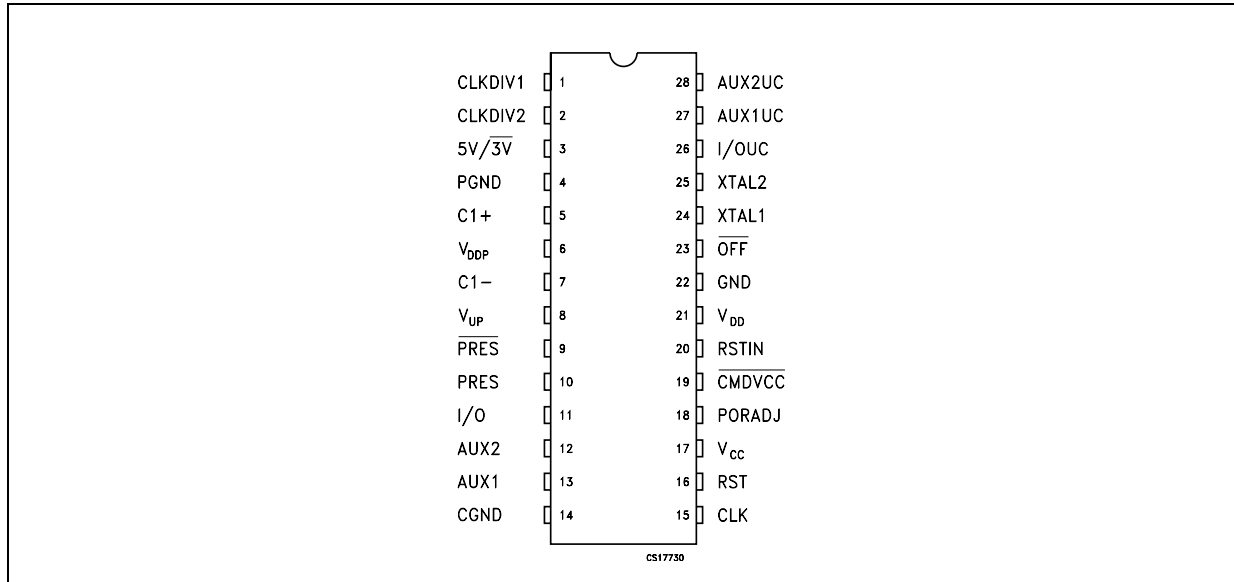

Table 1. Pin description

| Pin N° | Symbol | Name and function |
|--------|----------------------------|---|
| 1 | CLKDIV1 | Control of CLK Frequency |
| 2 | CLKDIV2 | Control of CLK Frequency |
| 3 | 5V/3V | V _{CC} selection pin. |
| 4 | PGND | Power Ground for Step-Up converter |
| 5 | C1+ | External Cap. for Step-Up converter |
| 6 | V _{DDP} | Power Supply for Step-Up converter |
| 7 | C1- | External Cap. Step-Up converter |
| 8 | V _{UP} | Output of Step-Up converter |
| 9 | $\overline{\text{PRES}}$ | Card Presence Input (Active Low) |
| 10 | PRES | Card Presence Input (Active High) |
| 11 | I/O | Data Line to and from card (C7) (internal 11kΩ pull-up resistor connected to V _{CC}) |
| 12 | AUX2 | Auxiliary line to and from card (C8) (internal 11kΩ pull-up resistor connected to V _{CC}) |
| 13 | AUX1 | Auxiliary line to and from card (C4) (internal 11kΩ pull-up resistor connected to V _{CC}) |
| 14 | CGND | Ground for card signal (C5) |
| 15 | CLK | Clock to card (C3) |
| 16 | RST | Card Reset (C2) |
| 17 | V _{CC} | Supply Voltage for the card (C1) |
| 18 | V _{THSEL} | Deactivation threshold selector pin (under voltage lock-out) |
| 19 | $\overline{\text{CMDVCC}}$ | Start activation sequence input (Active Low) |

Table 1. Pin description

| Pin N° | Symbol | Name and function |
|--------|-------------------------|---|
| 20 | RSTIN | Card Reset Input from MCU |
| 21 | V _{DD} | Supply Voltage |
| 22 | GND | Ground |
| 23 | $\overline{\text{OFF}}$ | Interrupt to MCU (active Low) |
| 24 | XTAL1 | Crystal or external clock input |
| 25 | XTAL2 | Crystal connection (leave this pin open if external clock is used) |
| 26 | I/OUC | MCU data I/O line (internal 11k Ω pull-up resistor connected to V _{DD}) |
| 27 | AUX1UC | Non-inverting Receiver Input (internal 11k Ω pull-up resistor connected to V _{DD}) |
| 28 | AUX2UC | Non-inverting Receiver Input (internal 11k Ω pull-up resistor connected to V _{DD}) |

3 Maximum ratings

Table 2. Absolute maximum ratings

| Symbol | Parameter | Min | Max | Unit |
|-------------------|---|------|----------------|------|
| V_{DD}, V_{DDP} | Supply Voltage | -0.3 | 7 | V |
| V_{n1} | Voltage on pins XTAL1, XTAL2, $5V/3V$, RSTIN, AUX2UC, AUX1UC, I/OUC, CLKDIV1, CLKDIV2, PORADJ, \overline{CMDVCC} , \overline{PRES} , PRES and \overline{OFF} | -0.3 | $V_{DD} + 0.3$ | V |
| V_{n2} | Voltage on card contact pins I/O, RST, AUX1, AUX2 and CLK | -0.3 | $V_{CC} + 0.3$ | V |
| V_{n3} | Voltage on pins V_{UP} S1 and S2 | | 7 | V |
| ESD1 | MIL-STD-883 class 3 on card contact pins, \overline{PRES} and PRES (Note: 1, 2) | -6 | 6 | kV |
| ESD2 | MIL-STD-883 class 2 on μC contact pins and RSTIN (Note 1, 2) | -2 | 2 | kV |
| $T_{J(MAX)}$ | Maximum Operating Junction Temperature | | 150 | °C |
| T_{STG} | Storage Temperature Range | -40 | 150 | °C |

Note: Absolute Maximum Ratings are those values beyond which damage to the device may occur. Functional operation under these conditions is not implied.

- Note: 1 All card contacts are protected against any short with any other card contact.
 2 Method 3015 (HBM, 1500 Ω , 100 pF) 3 positive pulses and 3 negative pulses on each pin referenced to ground.

Table 3. Thermal data

| Symbol | Parameter | Condition | SO-28 | TSSOP28 | Unit |
|------------|---|--|-------|---------|------|
| R_{thJA} | Thermal resistance junction-ambient temperature | Multilayer test board (Jedec standard) | 56 | 50 | °K/W |

Table 4. Recommended operating conditions

| Symbol | Parameter | Test Conditions | Min. | Typ. | Max. | Unit |
|--------|-------------------|-----------------|------|------|------|------|
| T_A | Temperature range | | -25 | | 85 | °C |

4 Electrical characteristics

Table 5. Electrical characteristics over recommended operating condition ($V_{DD} = 3.3V$, $V_{DDP} = 5V$, $f_{XTAL} = 10MHz$, unless otherwise noted. Typical values are to $T_A = 25^\circ C$)

| Symbol | Parameter | Test Conditions | Min. | Typ. | Max. | Unit |
|-----------------------|--|---|------|------|------|---------|
| V_{DD} | Supply voltage | | 2.7 | | 6.5 | V |
| V_{DDP} | Supply voltage for the voltage doubler | $V_{CC} = 5V$; $ I_{CC} < 80$ mA | 4.0 | 5 | 6.5 | V |
| | | $V_{CC} = 5V$; $ I_{CC} < 20$ mA | 3.0 | | 6.5 | |
| I_{DD} | Supply current | Card Inactive | | | 1.2 | mA |
| | | Card Active; $f_{CLK} = f_{XTAL}$; $C_L = 30pF$ | | | 1.5 | |
| I_{DDP} | DC/DC converter supply current | Inactive mode | | | 0.1 | mA |
| | | Active mode; $f_{CLK} = f_{XTAL}$; $C_L = 30pF$; $ I_{CC} = 0$ | | | 10 | |
| | | $V_{CC} = 5V$; $ I_{CC} = 80$ mA | | | 200 | |
| | | $V_{CC} = 3V$; $ I_{CC} = 65$ mA | | | 100 | |
| V_{th2} | Falling threshold voltage on V_{DD} | no external resistors at pin PORADJ; V_{DD} level falling | 2.35 | 2.45 | 2.55 | V |
| V_{HYS2} | Hysteresis of threshold voltage V_{th2} | no external resistors at pin PORADJ | 50 | 100 | 150 | mV |
| $V_{th(ext)rise}$ | External rising threshold voltage on V_{DD} | external resistor bridge at pin PORADJ; V_{DD} level rising | 1.25 | 1.28 | 1.31 | V |
| $V_{th(ext)fall}$ | External falling threshold voltage on V_{DD} | external resistor bridge at pin PORADJ; V_{DD} level falling | 1.19 | 1.22 | 1.25 | V |
| $V_{HYS(ext)}$ | Hysteresis of threshold voltage $V_{th(ext)}$ | external resistor bridge at pin PORADJ | 30 | 60 | 90 | mV |
| $\Delta V_{HYS(ext)}$ | Hysteresis of threshold voltage $V_{th(ext)}$ variation with temperature | external resistor bridge at pin PORADJ | | | 0.25 | mV/K |
| t_w | Width of internal Power-On reset pulse | no external resistor at pin PORADJ | 4 | 8 | 12 | ms |
| | | external resistor bridge at pin PORADJ | 8 | 16 | 24 | |
| I_L | Leakage current on pin PORADJ | $V_{PORADJ} < 0.5$ V | -0.1 | 4 | 10 | μA |
| | | $V_{PORADJ} > 1.0$ V | -1 | | 1 | |
| P_{TOT} | Total power dissipation | Continuous operation; $T_a = -25$ to $85^\circ C$ | | | 0.56 | W |

Table 6. Step-up Converter ($V_{DD} = 3.3V$, $V_{DDP} = 5V$, $f_{XTAL} = 10MHz$, unless otherwise noted. Typical values are to $T_a = 25^{\circ}C$)

| Symbol | Parameter | Test Conditions | Min. | Typ. | Max. | Unit |
|-----------------|---|------------------------------------|------|------|------|------|
| f_{CLK} | Clock Frequency | Card active | 2.2 | | 3.2 | MHz |
| $V_{th(vd-vf)}$ | Threshold voltage for Step-up Converter to change to voltage follower | 5 V card | 5.2 | 5.8 | 6.2 | V |
| | | 3 V card | 3.8 | 4.1 | 4.4 | |
| $V_{UP(av)}$ | Output Voltage on pin V_{UP} (average value) | $V_{CC} = 5 V$ | 5.2 | 5.7 | 6.2 | V |
| | | $V_{CC} = 3 V$; $V_{DDP} = 3.3 V$ | 3.5 | 3.9 | 4.3 | |

Table 7. Card supply voltage characteristics ($V_{DD} = 3.3V$, $V_{DDP} = 5V$, $f_{XTAL} = 10MHz$, unless otherwise noted. Typical values are to $T_A = 25^{\circ}C$) (Note 1)

| Symbol | Parameter | Test Conditions | Min. | Typ. | Max. | Unit | |
|-------------------------|---|---|---------------|------|------|------------|---|
| C_{VCC} | External capacitance on pin V_{CC} | <i>Note 2 and Note 3</i> | 80 | | 220 | nF | |
| V_{CC} | Card supply voltage (including ripple voltage) | Card Inactive; $ I_{CC} = 0 mA$ | 5 and 3V card | -0.1 | 0 | 0.1 | V |
| | | Card Inactive; $ I_{CC} = 1 mA$ | 5 and 3V card | -0.1 | 0 | 0.3 | |
| | | Card Active; $ I_{CC} < 80 mA$ | 5 V card | 4.75 | 5 | 5.25 | |
| | | Card Active; $ I_{CC} < 65 mA$ | 3 V card | 2.85 | 3 | 3.15 | |
| | | Card Active; single current pulse $I_P = -100 mA$; $t_p = 2 \mu s$ | 5 V card | 4.65 | 5 | 5.25 | |
| | | Card Active; single current pulse $I_P = -100 mA$; $t_p = 2 \mu s$ | 3 V card | 2.76 | 3 | 3.20 | |
| | | Card active; current pulses, $Q_P = 40 nAs$ | 5 V card | 4.65 | 5 | 5.25 | |
| | | | 3 V card | 2.76 | 3 | 3.20 | |
| | | Card Active; current pulses $Q_P = 40 nAs$ with $ I_{CC} < 200mA$, $t_p < 400 ns$ | 5 V card | 4.65 | 5 | 5.25 | |
| 3 V card | 2.76 | | 3 | 3.20 | | | |
| $V_{CC} (RIPPLE) (P-P)$ | Ripple voltage on V_{CC} (Peak to Peak value) | $f_{RIPPLE} = 20 KHz$ to $200 MHz$ | | | 350 | mV | |
| $ I_{CC} $ | Card supply current | $V_{CC} = 0$ to $5V$ | | | 80 | mA | |
| | | $V_{CC} = 0$ to $3V$ | | | 65 | | |
| | | V_{CC} short circuit to GND | 90 | | 120 | | |
| S_R | Slew rate | Slew up or down | 0.08 | 0.15 | 0.22 | V/ μs | |

Table 8. Crystal connection (pins XTAL1 and XTAL2) ($V_{DD} = 3.3V$, $V_{DDP} = 5V$, $f_{XTAL} = 10MHz$, unless otherwise noted. Typical values are to $T_A = 25^\circ C$)

| Symbol | Parameter | Test Conditions | Min. | Typ. | Max. | Unit |
|---------------|---|--|--------------|------|--------------|------|
| $C_{XTAL1,2}$ | External capacitance on pins XTAL1, XTAL2 | Depends on type of crystal or resonator used | | | 15 | pF |
| f_{XTAL} | Crystal Frequency | | 2 | | 26 | MHz |
| f_{XTAL1} | Frequency applied on pin XTAL1 | | 0 | | 26 | MHz |
| V_{IH} | High level input voltage on pin XTAL1 | | $0.7 V_{DD}$ | | $V_{DD}+0.3$ | V |
| V_{IL} | Low level input voltage on pin XTAL1 | | -0.3 | | $+0.3V_{DD}$ | V |

Table 9. Data Lines (PINS I/O, I/OUC, AUX1, AUX2, AUX1UC AND AUX2UC) ($V_{DD} = 3.3V$, $V_{DDP} = 5V$, $f_{XTAL} = 10MHz$, unless otherwise noted. Typical values are to $T_A = 25^\circ C$)

| Symbol | Parameter | Test Conditions | Min. | Typ. | Max. | Unit |
|--|---|-----------------|------|------|------|------|
| $t_{D(I/O-I/OUC)}$, $t_{D(I/OUC-I/O)}$ | I/O to I/OUC, I/OUC to I/O falling edge delay | | | | 200 | ns |
| t_{pu} | Active pull-up pulse width | | | | 100 | ns |
| $f_{I/O(MAX)}$ | Maximum frequency on data lines | | | | 1 | MHz |
| C_I | Input capacitance on data lines | | | | 10 | pF |

Table 10. Data lines to card reader (pins I/O, AUX1 AND AUX2 with integrated 11k Ω Pull-up resistor to V_{CC}) ($V_{DD} = 3.3V$, $V_{DDP} = 5V$, $f_{XTAL} = 10MHz$, unless otherwise noted. Typical values are to $T_A = 25^\circ C$)

| Symbol | Parameter | Test Conditions | Min. | Typ. | Max. | Unit | |
|-------------------|----------------------------------|--------------------------------------|-----------------------|------|--------------|------------|---|
| $V_{O(inactive)}$ | Output Voltage | Inactive mode | NO LOAD | 0 | | 0.1 | V |
| | | | $I_{O(inactive)}=1mA$ | | | 0.3 | |
| $I_{O(inactive)}$ | Output Current | Inactive mode; pin grounded | | | -1 | mA | |
| V_{OH} | High Level Output Voltage | No DC Load | $0.9 V_{CC}$ | | $V_{CC}+0.1$ | V | |
| | | 5 and 3 V cards; $I_{OH} < -40\mu A$ | $0.75 V_{CC}$ | | $V_{CC}+0.1$ | | |
| | | $ I_{OH} \geq 10mA$ | 0 | | 0.4 | | |
| V_{OL} | Low Level Output Voltage | $I_{OL} = 1 mA$ | 0 | | 0.2 | V | |
| | | $I_{OL} \geq 15 mA$ | $V_{CC}-0.4$ | | V_{CC} | | |
| V_{IH} | High Level Input Voltage | | 1.5 | | $V_{CC}+0.3$ | V | |
| V_{IL} | Low Level Input Voltage | | 0.3 | | 0.8 | V | |
| $ I_{LIH} $ | High Level Input Leakage Current | $V_{IH} = V_{CC}$ | | | 10 | μA | |
| $ I_{LIL} $ | Low Level Input Current | $V_{IL} = 0 V$ | | | 600 | μA | |
| R_{PU} | Integrated pull-up resistor | Pull-up resistor to V_{CC} | 9 | 11 | 13 | k Ω | |

Table 10. Data lines to card reader (pins I/O, AUX1 AND AUX2 with integrated 11kΩ Pull-up resistor to V_{CC}) (V_{DD} = 3.3V, V_{D DP} = 5V, f_{X TAL} = 10MHz, unless otherwise noted. Typical values are to T_A = 25°C)

| Symbol | Parameter | Test Conditions | Min. | Typ. | Max. | Unit |
|--------------------|-----------------------------|--|------|------|------|------|
| t _{T(DI)} | Data Input transition time | V _{IL} max to V _{IH} min | | | 1.2 | μs |
| t _{T(DO)} | Data Output transition time | V _O = 0 to V _{CC} ; C _L ≤ 80 pF; 10% to 90% | | | 0.1 | μs |
| I _{PU} | Current when pull-up active | V _{OH} = 0.9V _{CC} ; C _L = 80 pF | -1 | | | mA |

Table 11. Data lines to microcontroller (pins I/OUC, AUX1UC AND AUX2UC with integrated 11kΩ Pull-up resistor to V_{DD}) (V_{DD} = 3.3V, V_{D DP} = 5V, f_{X TAL} = 10MHz, unless otherwise noted. Typical values are to T_A = 25°C)

| Symbol | Parameter | Test Conditions | Min. | Typ. | Max. | Unit |
|--------------------|--|--|----------------------|------|----------------------|------|
| V _{OH} | High Level Output Voltage | 5 and 3 V card; I _{OH} < -40μA | 0.75 V _{DD} | | V _{DD} +0.1 | V |
| | | No DC Load | 0.9 V _{DD} | | V _{DD} +0.1 | |
| V _{OL} | Low Level Output Voltage | I _{OL} = 1 mA | 0 | | 0.3 | V |
| V _{IH} | High Level Input Voltage | | 0.7 V _{DD} | | V _{DD} +0.3 | V |
| V _{IL} | Low Level Input Voltage | | -0.3 | | 0.3 V _{DD} | V |
| I _{L IH} | High Level Input Leakage Current | V _{IH} = V _{DD} | | | 10 | μA |
| I _{L L} | Low Level Input Current | V _{IL} = 0 V | | | 600 | μA |
| R _{PU} | Internal pull-up resistance to V _{DD} | Pull-up resistor to V _{DD} | 9 | 11 | 13 | kΩ |
| t _{T(DI)} | Data Input transition time | V _{IL(max)} to V _{IH(min)} | | | 1.2 | μs |
| t _{T(DO)} | Data Output transition time | V _O = 0 to V _{DD} ; C _L < 30 pF; 10% to 90% | | | 0.1 | μs |
| I _{PU} | Current when pull-up active | V _{OH} = 0.9V _{DD} ; C _L = 30 pF | -1 | | | mA |

Table 12. Internal oscillator (V_{DD} = 3.3V, V_{D DP} = 5V, f_{X TAL} = 10MHz, unless otherwise noted. Typical values are to T_A = 25°C)

| Symbol | Parameter | Test Conditions | Min. | Typ. | Max. | Unit |
|-----------------------|----------------------------------|-----------------|------|------|------|------|
| f _{OSC(INT)} | Frequency of internal oscillator | Inactive mode | 55 | 140 | 200 | kHz |
| | | Active mode | 2.2 | 2.7 | 3.2 | MHz |

Table 13. Reset output to card reader (pin RST) ($V_{DD} = 3.3V$, $V_{DDP} = 5V$, $f_{XTAL} = 10MHz$, unless otherwise noted. Typical values are to $T_A = 25^\circ C$)

| Symbol | Parameter | Test Conditions | Min. | Typ. | Max. | Unit |
|--------------------|---------------------------------|--|--------------|------|----------|---------|
| $V_{O(inactive)}$ | Output Voltage in Inactive Mode | $I_{O(inactive)} = 1\text{ mA}$ | 0 | | 0.3 | V |
| | | No Load | 0 | | 0.1 | |
| $I_{O(inactive)}$ | Output Current | Inactive mode; pin grounded | 0 | | -1 | mA |
| $t_{D(RSTIN-RST)}$ | RSTN to RST Delay | RST Enable | | | 2 | μs |
| V_{OL} | Low Level Output Voltage | $I_{OL} = 200\ \mu A$ | 0 | | 0.2 | V |
| | | $I_{OL} = 20\text{ mA (current limit)}$ | $V_{CC}-0.4$ | | V_{CC} | |
| V_{OH} | High Level Output Voltage | $I_{OH} = -200\ \mu A$ | $0.9V_{CC}$ | | V_{CC} | V |
| | | $I_{OH} = -20\text{ mA (current limit)}$ | 0 | | 0.4 | |
| t_R, t_F | Rise and fall time | $C_L = 100\text{ pF}; V_{CC} = 5\text{ or }3\text{ V}$ | | | 0.1 | μs |

Table 14. Clock output to card reader (pin CLK) ($V_{DD} = 3.3V$, $V_{DDP} = 5V$, $f_{XTAL} = 10MHz$, unless otherwise noted. Typical values are to $T_A = 25^\circ C$)

| Symbol | Parameter | Test Conditions | Min. | Typ. | Max. | Unit |
|-------------------|---------------------------------------|--|--------------|------|----------|------|
| $V_{O(inactive)}$ | Output voltage in inactive mode | $I_{O(inactive)} = 1\text{ mA}$ | 0 | | 0.3 | V |
| | | No Load | 0 | | 0.1 | |
| $I_{O(inactive)}$ | Output current | CLK Inactive mode; pin grounded | 0 | | -1 | mA |
| V_{OL} | Low level output voltage | $I_{OL} = 200\ \mu A$ | 0 | | 0.3 | V |
| | | $I_{OL} = 70\text{ mA (current limit)}$ | $V_{CC}-0.4$ | | V_{CC} | |
| V_{OH} | High level output voltage | $I_{OH} = -200\ \mu A$ | $0.9V_{CC}$ | | V_{CC} | V |
| | | $I_{OH} = -70\text{ mA (current limit)}$ | 0 | | 0.4 | |
| t_R, t_F | Rise and fall time | $C_L = 30\text{ pF (Note 4)}$ | | | 16 | ns |
| δ | Duty factor (except for f_{XTALS}) | $C_L = 30\text{ pF (Note 4)}$ | 45 | | 55 | % |
| S_R | Slew rate | Slew up or down; $C_L = 30\text{ pF}$ | 0.2 | | | V/ns |

Table 15. Control inputs (PINS CLKDIV1, CLKDIV2, $\overline{\text{CMDVCC}}$, RSTIN AND $5V\sqrt{3V}$)
 ($V_{DD} = 3.3V$, $V_{DDP} = 5V$, $f_{XTAL} = 10MHz$, unless otherwise noted. Typical values are to $T_a = 25^\circ C$) (*Note 5*)

| Symbol | Parameter | Test Conditions | Min. | Typ. | Max. | Unit |
|--------------|----------------------------|-------------------|-------------|------|-------------|---------|
| V_{IL} | Input voltage LOW | | -0.3 | | $0.3V_{DD}$ | V |
| V_{IH} | Input voltage HIGH | | $0.7V_{DD}$ | | V_{DD} | V |
| $ I_{L IH} $ | Input leakage current HIGH | $V_{IH} = V_{DD}$ | | | 1 | μA |
| $ I_{L L} $ | Input leakage current LOW | $V_{IL} = 0$ | | | 1 | μA |

Table 16. Card presence inputs (PINS PRES AND $\overline{\text{PRES}}$)
 ($V_{DD} = 3.3V$, $V_{DDP} = 5V$, $f_{XTAL} = 10MHz$, unless otherwise noted. Typical values are to $T_a = 25^\circ C$) (*Note 6*)

| Symbol | Parameter | Test Conditions | Min. | Typ. | Max. | Unit |
|--------------|----------------------------|-------------------|--------------|------|--------------|---------|
| V_{IL} | Input Voltage LOW | | -0.3 | | $0.3 V_{DD}$ | V |
| V_{IH} | Input Voltage HIGH | | $0.7 V_{DD}$ | | $V_{DD}+0.3$ | V |
| $ I_{L IH} $ | Input Leakage Current HIGH | $V_{IH} = V_{DD}$ | | | 5 | μA |
| $ I_{L L} $ | Input Leakage Current LOW | $V_{IL} = 0$ | | | 5 | μA |

Table 17. Interrupt Output (PIN $\overline{\text{OFF}}$ NMOS Drain With Integrated 20 k Ω PULL-UP Resistor To V_{DD}); ($V_{DD} = 3.3V$, $V_{DDP} = 5V$, $f_{XTAL} = 10MHz$, unless otherwise noted. Typical values are to $T_a = 25^\circ C$)

| Symbol | Parameter | Test Conditions | Min. | Typ. | Max. | Unit |
|----------|-----------------------------|---|---------------|------|------|------------|
| V_{OL} | Low Level Output Voltage | $I_{OL} = 2 \text{ mA}$ | 0 | | 0.3 | V |
| V_{OH} | High Level Output Voltage | $I_{OH} = -15 \mu A$ | $0.75 V_{DD}$ | | | V |
| R_{PU} | Integrated pull-up resistor | 20k Ω Pull-up resistor to V_{DD} | 16 | 20 | 24 | k Ω |

Table 18. Protection And Limitation ($V_{DD} = 3.3V$, $V_{DDP} = 5V$, $f_{XTAL} = 10MHz$, unless otherwise noted. Typical values are to $T_a = 25^\circ C$)

| Symbol | Parameter | Test Conditions | Min. | Typ. | Max. | Unit |
|----------------|--|-----------------|------|------|------|------------|
| $ I_{CC(SD)} $ | Shutdown and limitation current pin V_{CC} | | 90 | | 120 | mA |
| $I_{I/O(lim)}$ | limitation current pins I/O, AUX1 and AUX2 | | -15 | | 15 | mA |
| $I_{CLK(lim)}$ | limitation current pin CLK | | -70 | | 70 | mA |
| $I_{RST(lim)}$ | limitation current pin RST | | -20 | | 20 | mA |
| T_{SD} | Shut down temperature | | | 150 | | $^\circ C$ |

Table 19. Timing ($V_{DD} = 3.3V$, $V_{DDP} = 5V$, $f_{XTAL} = 10MHz$, unless otherwise noted. Typical values are to $T_A = 25^\circ C$)

| Symbol | Parameter | Test Conditions | Min. | Typ. | Max. | Unit |
|----------------|---|----------------------------------|------|------|------|---------|
| t_{ACT} | Activation time | (See Figure 5.) | | 180 | 220 | μs |
| t_{DE} | Deactivation time | (See Figure 7.) | 60 | 80 | 100 | μs |
| t_3 | Start of the windows for sending CLK to card | (See Figure 6.) | | | 130 | μs |
| t_5 | End of the windows for sending CLK to card | (See Figure 6.) | 140 | | | μs |
| $t_{debounce}$ | Debounce time pins PRES and \overline{PRES} | (See Figure 8.) | 140 | | | μs |

- Note:
- 1 All parameters remain within limits but are tested only statistically for the temperature range. When a parameter is specified as a function of V_{DD} or V_{CC} it means their actual value at the moment of measurement.
 - 2 To meet these specifications, pin V_{CC} should be decoupled to CGND using two ceramic multilayer capacitors of low ESR both with values of 100 nF and 100 nF (see [Figure 10.](#)).
 - 3 Permitted capacitor values are 100 + 100 nF, or 220 nF.
 - 4 Transition time and duty factor definitions are shown in [Figure 3.](#); $\delta = t_1/(t_1 + t_2)$.
 - 5 Pin \overline{CMDVCC} is active LOW; pin RSTIN is active HIGH; for CLKDIV1 and CLKDIV2 functions see [Table 19.](#)
 - 6 Pin \overline{PRES} is active LOW; pin PRES is active HIGH see [Figure 8.](#) and [Figure 9.](#); PRES has an integrated 1.25 μA current source to GND. (PRES to V_{DD}); the card is considered present if at least one of the inputs PRES or \overline{PRES} is active.

Figure 3. Definition of output and input transition times

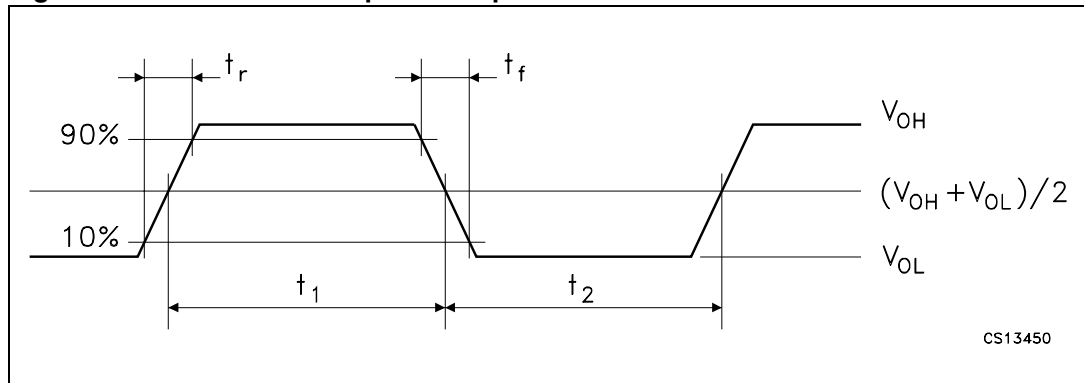

5 Functional description

Throughout this document it is assumed that the reader is familiar with ISO7816 terminology.

5.1 Power supply

The supply pins for the IC are V_{DD} and GND. V_{DD} should be in the range of 2.7 to 6.5 V. All signals interfacing with the system controller are referred to V_{DD} , therefore V_{DD} should also supply the system controller. All card reader contacts remain inactive during power-on or power-off.

The internal circuits are maintained in the reset state until V_{DD} reaches $V_{th2} + V_{hys2}$ and for the duration of the internal Power-on reset pulse, t_W (see [Figure 4.](#)). When V_{DD} falls below V_{th2} , an automatic deactivation of the contacts is performed.

A DC/DC converter is incorporated to generate the 5 or 3 V card supply voltage (V_{CC}). The DC/DC converter should be supplied separately by V_{DDP} and PGND. Due to the possibility of large transient currents, the two 100 nF capacitors of the DC/DC converter should be located as near as possible to the IC and have an ESR less than 100 m Ω .

The DC/DC converter functions as a voltage doubler or a voltage follower according to the respective values of V_{CC} and V_{DDP} (both have thresholds with a hysteresis of 100 mV).

The DC/DC converter function changes as follows:

$V_{CC} = 5$ V and $V_{DDP} > 5.8$ V; voltage follower

$V_{CC} = 5$ V and $V_{DDP} < 5.7$ V; voltage doubler

$V_{CC} = 3$ V and $V_{DDP} > 4.1$ V; voltage follower

$V_{CC} = 3$ V and $V_{DDP} < 4.0$ V; voltage doubler.

Supply voltages V_{DD} and V_{DDP} may be applied to the IC in any sequence.

After powering the device, OFF remains LOW until \overline{CMDVCC} is set HIGH.

During power off, OFF falls LOW when V_{DD} is below the falling threshold voltage.

5.2 Voltage supervisor

5.2.1 Without external divider on pin PORADJ

The voltage supervisor surveys the V_{DD} supply. A defined reset pulse of approximately 8ms (t_W) is used internally to keep the IC inactive during power-on or power-off of the V_{DD} supply (see [Figure 4.](#)).

As long as V_{DD} is less than $V_{th2} + V_{hys2}$, the IC remains inactive whatever the levels on the command lines. This state also lasts for the duration of t_W after V_{DD} has reached a level higher than $V_{th2} + V_{hys2}$. When V_{DD} falls below V_{th2} , a deactivation sequence of the contacts is performed.

Figure 4. Voltage supervisor

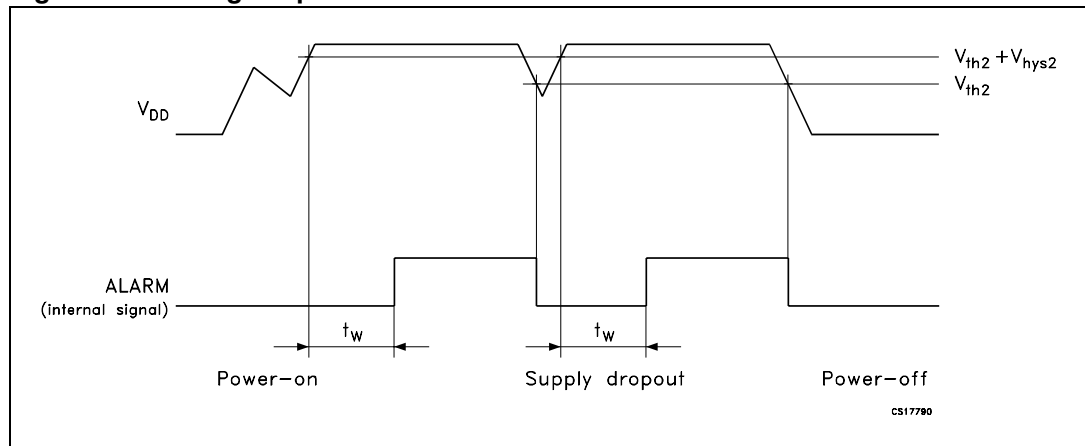

5.2.2 With an external divider on pin PORADJ

If an external resistor bridge is connected to pin PORADJ (R1 and R2 in [Figure 1.](#)), then the following occurs:

- The internal threshold voltage V_{th2} is overridden by the external voltage and by the hysteresis, therefore:

$$V_{th2(ext)(rise)} = (1 + R1/R2) \times (V_{bridge} + V_{hys(ext)}/2)$$

$$V_{th2(ext)(fall)} = (1 + R1/R2) \times (V_{bridge} - V_{hys(ext)}/2)$$

where $V_{bridge} = 1.25 \text{ V typ.}$ and $V_{hys(ext)} = 60 \text{ mV typ.}$

- The reset pulse width t_w is doubled to approximately 16 ms.

Input PORADJ is biased internally with a pull-down current source of $4 \mu\text{A}$ which is removed when the voltage on pin PORADJ exceeds 1 V.

This ensures that after detection of the external bridge by the IC during power-on, the input current on pin PORADJ does not cause inaccuracy of the bridge voltage.

The minimum threshold voltage should be higher than 2 V. The maximum threshold voltage may be up to V_{DD} .

5.2.3 Application examples

The voltage supervisor is used as Power-on reset and as supply dropout detection during a card session. Supply dropout detection is to ensure that a proper deactivation sequence is followed before the voltage is too low. For the internal voltage supervisor to function, the system microcontroller should operate down to 2.35 V to ensure a proper deactivation sequence. If this is not possible, external resistor values can be chosen to overcome the problem.

5.3 Clock circuitry

The card clock signal (CLK) is derived from a clock signal input to pin XTAL1 or from a crystal operating at up to 26 MHz connected between pins XTAL1 and XTAL2.

The clock frequency can be f_{XTAL} , $1/2 \times f_{XTAL}$, $1/4 \times f_{XTAL}$ or $1/8 \times f_{XTAL}$. Frequency selection is made via inputs CLKDIV1 and CLKDIV2 (see Table 20).

Table 20. Clock frequency selection ⁽¹⁾

| CLKDIV1 | CLKDIV2 | f _{CLK} |
|---------|---------|----------------------|
| 0 | 0 | f _{XTAL} /8 |
| 0 | 1 | f _{XTAL} /4 |
| 1 | 1 | f _{XTAL} /2 |
| 1 | 0 | f _{XTAL} |

1. The status of pins CLKDIV1 and CLKDIV2 must not be changed simultaneously; a delay of 10 ns minimum between changes is needed; the minimum duration of any state of CLK is eight periods of XTAL1.

The frequency change is synchronous, which means that during transition no pulse is shorter than 45% of the smallest period, and that the first and last clock pulses about the instant of change have the correct width.

When changing the frequency dynamically, the change is effective for only eight periods of XTAL1 after the command. The duty factor of f_{XTAL} depends on the signal present at pin XTAL1. In order to reach a 45 to 55% duty factor on pin CLK, the input signal on pin XTAL1 should have a duty factor of 48 to 52% and transition times of less than 5% of the input signal period.

If a crystal is used, the duty factor on pin CLK may be 45 to 55% depending on the circuit layout and on the crystal characteristics and frequency. In other cases, the duty factor on pin CLK is guaranteed between 45 and 55% of the clock period.

The crystal oscillator runs as soon as the IC is powered up. If the crystal oscillator is used, or if the clock pulse on pin XTAL1 is permanent, the clock pulse is applied to the card as shown in the activation sequences shown in [Figure 5](#). and [Figure 6](#).

If the signal applied to XTAL1 is controlled by the system microcontroller, the clock pulse will be applied to the card when it is sent by the system microcontroller (after completion of the activation sequence).

5.4 I/O Transceivers

The three data lines I/O, AUX1 and AUX2 are identical. The idle state is realized by both I/O and I/OUC lines being pulled HIGH via a 11 kΩ resistor (I/O to V_{CC} and I/OUC to V_{DD}). Pin I/O is referenced to V_{CC}, and pin I/OUC to V_{DD}, thus allowing operation when V_{CC} is not equal to V_{DD}. The first side of the transceiver to receive a falling edge becomes the master. An anti-latch circuit disables the detection of falling edges on the line of the other side, which then becomes a slave. After a time delay t_{d(edge)}, an N transistor on the slave side is turned on, thus transmitting the logic 0 present on the master side. When the master side returns to logic 1, a P transistor on the slave side is turned on during the time delay t_{pu} and then both sides return to their idle states. This active pull-up feature ensures fast LOW-to-HIGH transitions; it is able to deliver more than 1 mA at an output voltage of up to 0.9 V_{CC} into an 80 pF load. At the end of the active pull-up pulse, the output voltage depends only on the internal pull-up resistor and the load current. The current to and from the card I/O lines is limited internally to 15 mA and the maximum frequency on these lines is 1 MHz.

5.5 Inactive mode

After a Power-on reset, the circuit enters the inactive mode. A minimum number of circuits are active while waiting for the microcontroller to start a session:

- All card contacts are inactive (approximately 200 Ω to GND)
- Pins I/OUC, AUX1UC and AUX2UC are in the high-impedance state (11 k Ω pull-up resistor to V_{DD})
- Voltage generators are stopped
- XTAL oscillator is running
- Voltage supervisor is active
- The internal oscillator is running at its low frequency.

5.6 Activation sequence

After power-on and after the internal pulse width delay, the system microcontroller can check the presence of a card using the signals $\overline{\text{OFF}}$ and $\overline{\text{CMDVCC}}$ as shown in [Table 21](#).

If the card is in the reader (this is the case if $\overline{\text{PRES}}$ or PRES is active), the system microcontroller can start a card session by pulling $\overline{\text{CMDVCC}}$ LOW. The following sequence then occurs (see [Figure 6](#)):

1. $\overline{\text{CMDVCC}}$ is pulled LOW and the internal oscillator changes to its high frequency (t_0).
2. The voltage doubler is started (between t_0 and t_1).
3. V_{CC} rises from 0 to 5 V (or 3 V) with a controlled slope ($t_2 = t_1 + 1.5 \times T$) where T is 64 times the period of the internal oscillator (approximately 25 μs).
4. I/O, AUX1 and AUX2 are enabled ($t_3 = t_1 + 4T$) (these were pulled LOW until this moment).
5. CLK is applied to the C3 contact of the card reader (t_4).
6. RST is enabled ($t_5 = t_1 + 7T$).

The clock may be applied to the card using the following sequence (see Fig.5):

1. Set RSTIN HIGH.
2. Set $\overline{\text{CMDVCC}}$ LOW.
3. Reset RSTIN LOW between t_3 and t_5 ; CLK will start at this moment.
4. RST remains LOW until t_5 , when RST is enabled to be the copy of RSTIN.
5. After t_5 , RSTIN has no further affect on CLK; this allows a precise count of CLK pulses before toggling RST.

If the applied clock is not needed, then $\overline{\text{CMDVCC}}$ may be set LOW with RSTIN LOW. In this case, CLK will start at t_3 (minimum 200 ns after the transition on I/O), and after t_5 , RSTIN may be set HIGH in order to obtain an Answer To Request (ATR) from the card.

Activation should not be performed with RSTIN held permanently HIGH

Table 21. Card presence indicator

| $\overline{\text{OFF}}$ | $\overline{\text{CMDVCC}}$ | Indication |
|-------------------------|----------------------------|------------------|
| H | H | card present |
| L | H | card not present |

Figure 5. Activation sequence using RSTIN and $\overline{\text{CMDVCC}}$

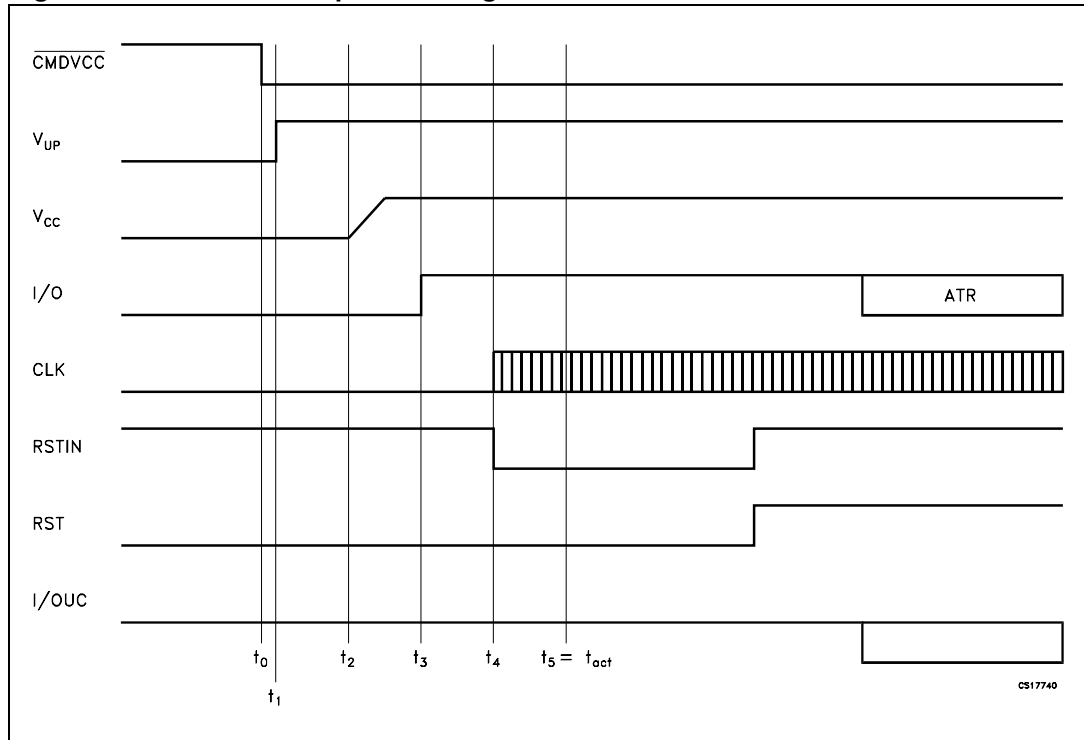
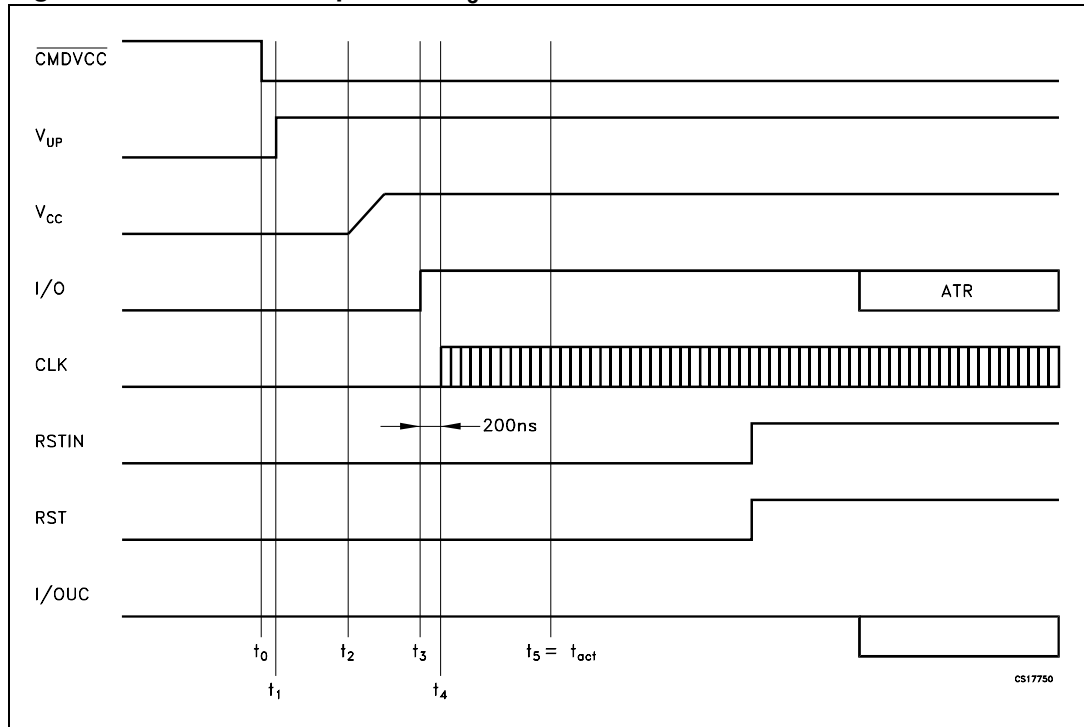

Figure 6. Activation sequence at t_3



5.7 Active mode

When the activation sequence is completed, the ST8024 will be in its active mode. Data are exchanged between the card and the microcontroller via the I/O lines.

The ST8024 is designed for cards without V_{PP} (the voltage required to program or erase the internal non-volatile memory).

5.8 Deactivation sequence

When a session is completed, the microcontroller sets the $\overline{\text{CMDVCC}}$ line HIGH. The circuit then executes an automatic deactivation sequence by counting the sequencer back and finishing in the inactive mode (see [Figure 7](#)):

1. RST goes LOW (t_{10}).
2. CLK is held LOW ($t_{12} = t_{10} + 0.5 \times T$) where T is 64 times the period of the internal oscillator (approximately 25 μs).
3. I/O, AUX1 and AUX2 are pulled LOW ($t_{13} = t_{10} + T$).
4. V_{CC} starts to fall towards zero ($t_{14} = t_{10} + 1.5 \times T$).
5. The deactivation sequence is complete at t_{de} , when V_{CC} reaches its inactive state.
6. V_{UP} falls to zero ($t_{15} = t_{10} + 5T$) and all card contacts become low-impedance to GND; I/OUC, AUX1UC and AUX2UC remain at V_{DD} (pulled-up via a 11 k Ω resistor).
7. The internal oscillator returns to its lower frequency.

Figure 7. Deactivation sequence

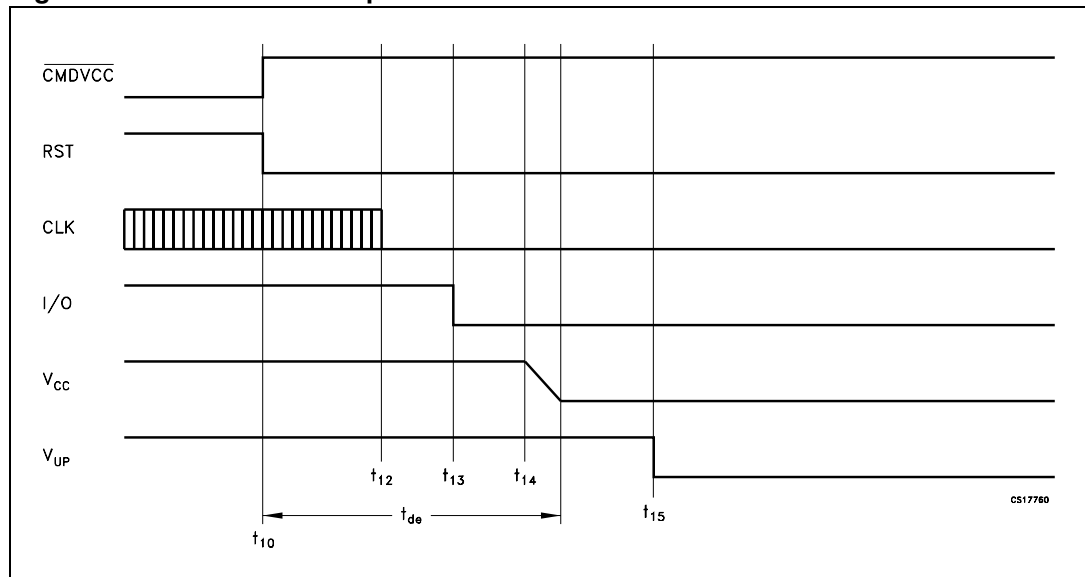

5.9 V_{CC} Generator

The V_{CC} generator has a capacity to supply up to 80 mA continuously at 5V and 65 mA at 3V. An internal overload detector operates at approximately 120 mA. Current samples to the detector are internally filtered, allowing spurious current pulses up to 200 mA with a duration in the order of μs to be drawn by the card without causing deactivation. The average current

must stay below the specified maximum current value. For reasons of V_{CC} voltage accuracy, a 100 nF capacitor with an ESR < 100 mΩ should be tied to CGND near to pin V_{CC} , and 100 nF capacitor with the same ESR should be tied to CGND near card reader contact C1.

5.10 Fault detection

The following fault conditions are monitored:

- Short-circuit or high current on V_{CC}
- Removal of a card during a transaction
- V_{DD} dropping
- DC/DC converter operating out of the specified values (V_{DDP} too low or current from V_{UP} too high)
- Overheating.
- There are two different cases (see [Figure 8](#)):
- \overline{CMDVCC} HIGH outside a card session. Output \overline{OFF} is LOW if a card is not in the card reader, and HIGH if a card is in the reader. A voltage drop on the V_{DD} supply is detected by the supply supervisor, this generates an internal Power-on reset pulse but does not act upon \overline{OFF} . No short-circuit or overheating is detected because the card is not powered-up.
- \overline{CMDVCC} LOW within a card session. Output \overline{OFF} goes LOW when a fault condition is detected. As soon as this occurs, an emergency deactivation is performed automatically (see [Figure 9](#)). When the system controller resets \overline{CMDVCC} to HIGH it may sense the \overline{OFF} level again after completing the deactivation sequence. This distinguishes between a hardware problem or a card extraction (\overline{OFF} goes HIGH again if a card is present).

Depending on the type of card-present switch within the connector (normally-closed or normally-open) and on the mechanical characteristics of the switch, bouncing may occur on the PRES signals at card insertion or withdrawal.

There is a debounce feature in the device with an 8 ms typical duration (see Fig.8). When a card is inserted, output \overline{OFF} goes HIGH only at the end of the debounce time.

When the card is extracted, an automatic deactivation sequence of the card is performed on the first true/false transition on PRES or \overline{PRES} and output \overline{OFF} goes LOW.

Figure 8. Behavior of \overline{OFF} , \overline{CMDVCC} , PRES and V_{CC}

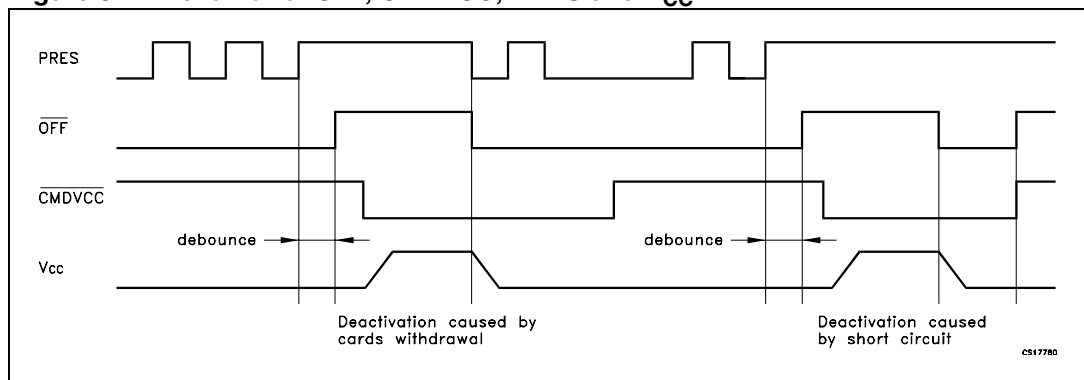
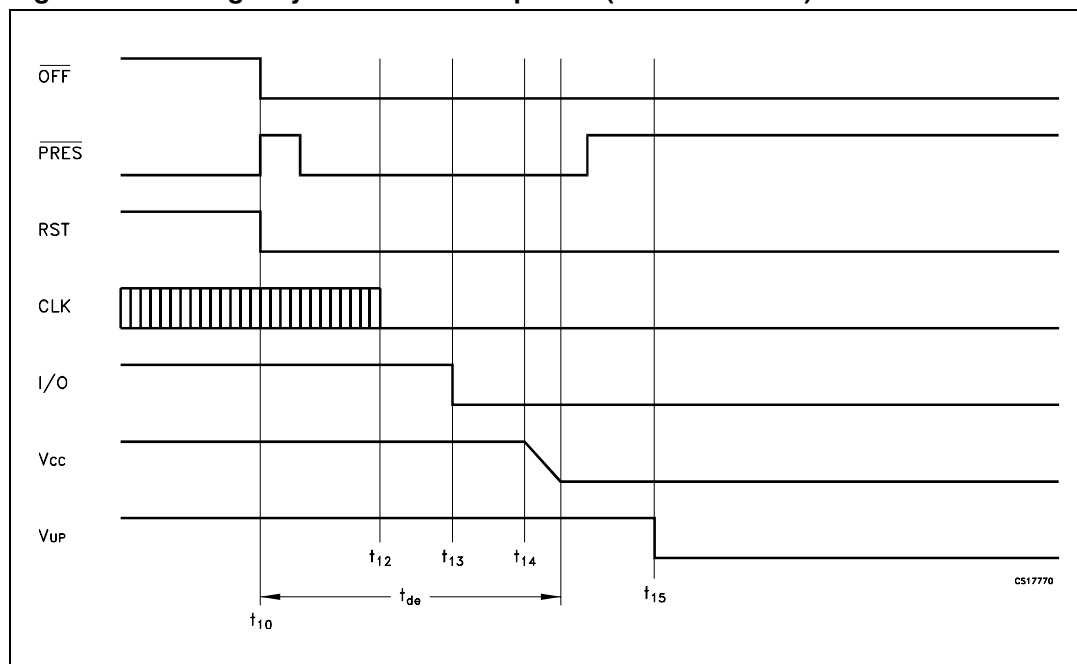

Figure 9. Emergency deactivation sequence (card extraction)



7 Package mechanical data

In order to meet environmental requirements, ST offers these devices in ECOPACK® packages. These packages have a Lead-free second level interconnect. The category of second level interconnect is marked on the package and on the inner box label, in compliance with JEDEC Standard JESD97. The maximum ratings related to soldering conditions are also marked on the inner box label. ECOPACK is an ST trademark. ECOPACK specifications are available at: www.st.com

SO-28 MECHANICAL DATA

| DIM. | mm. | | | inch | | |
|------|------------|-------|-------|-------|-------|-------|
| | MIN. | TYP | MAX. | MIN. | TYP. | MAX. |
| A | | | 2.65 | | | 0.104 |
| a1 | 0.1 | | 0.3 | 0.004 | | 0.012 |
| b | 0.35 | | 0.49 | 0.014 | | 0.019 |
| b1 | 0.23 | | 0.32 | 0.009 | | 0.012 |
| C | | 0.5 | | | 0.020 | |
| c1 | 45° (typ.) | | | | | |
| D | 17.70 | | 18.10 | 0.697 | | 0.713 |
| E | 10.00 | | 10.65 | 0.393 | | 0.419 |
| e | | 1.27 | | | 0.050 | |
| e3 | | 16.51 | | | 0.650 | |
| F | 7.40 | | 7.60 | 0.291 | | 0.300 |
| L | 0.50 | | 1.27 | 0.020 | | 0.050 |
| S | 8° (max.) | | | | | |

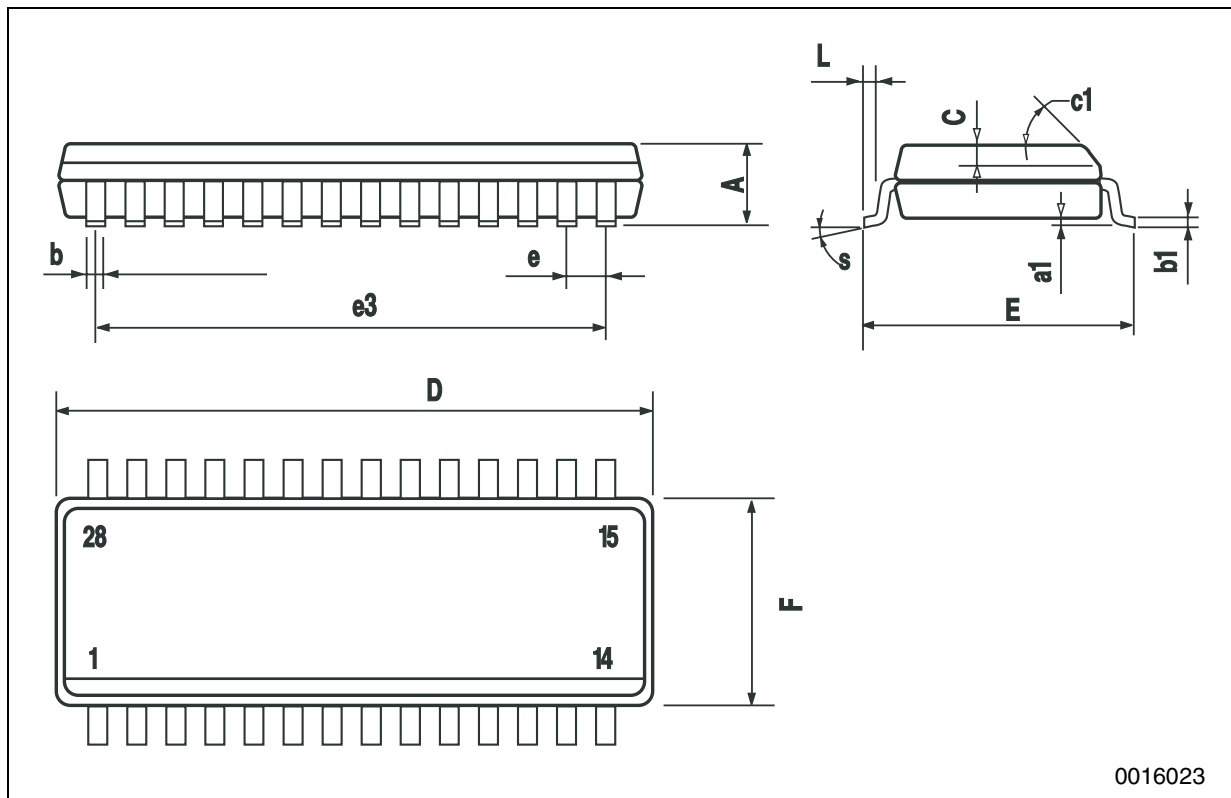

0016023

TSSOP28 MECHANICAL DATA

| DIM. | mm. | | | inch | | |
|------|------|----------|------|-------|------------|--------|
| | MIN. | TYP | MAX. | MIN. | TYP. | MAX. |
| A | | | 1.2 | | | 0.047 |
| A1 | 0.05 | | 0.15 | 0.002 | 0.004 | 0.006 |
| A2 | 0.8 | 1 | 1.05 | 0.031 | 0.039 | 0.041 |
| b | 0.19 | | 0.30 | 0.007 | | 0.012 |
| c | 0.09 | | 0.20 | 0.004 | | 0.0079 |
| D | 9.6 | 9.7 | 9.8 | 0.378 | 0.382 | 0.386 |
| E | 6.2 | 6.4 | 6.6 | 0.244 | 0.252 | 0.260 |
| E1 | 4.3 | 4.4 | 4.48 | 0.169 | 0.173 | 0.176 |
| e | | 0.65 BSC | | | 0.0256 BSC | |
| K | 0° | | 8° | 0° | | 8° |
| L | 0.45 | 0.60 | 0.75 | 0.018 | 0.024 | 0.030 |

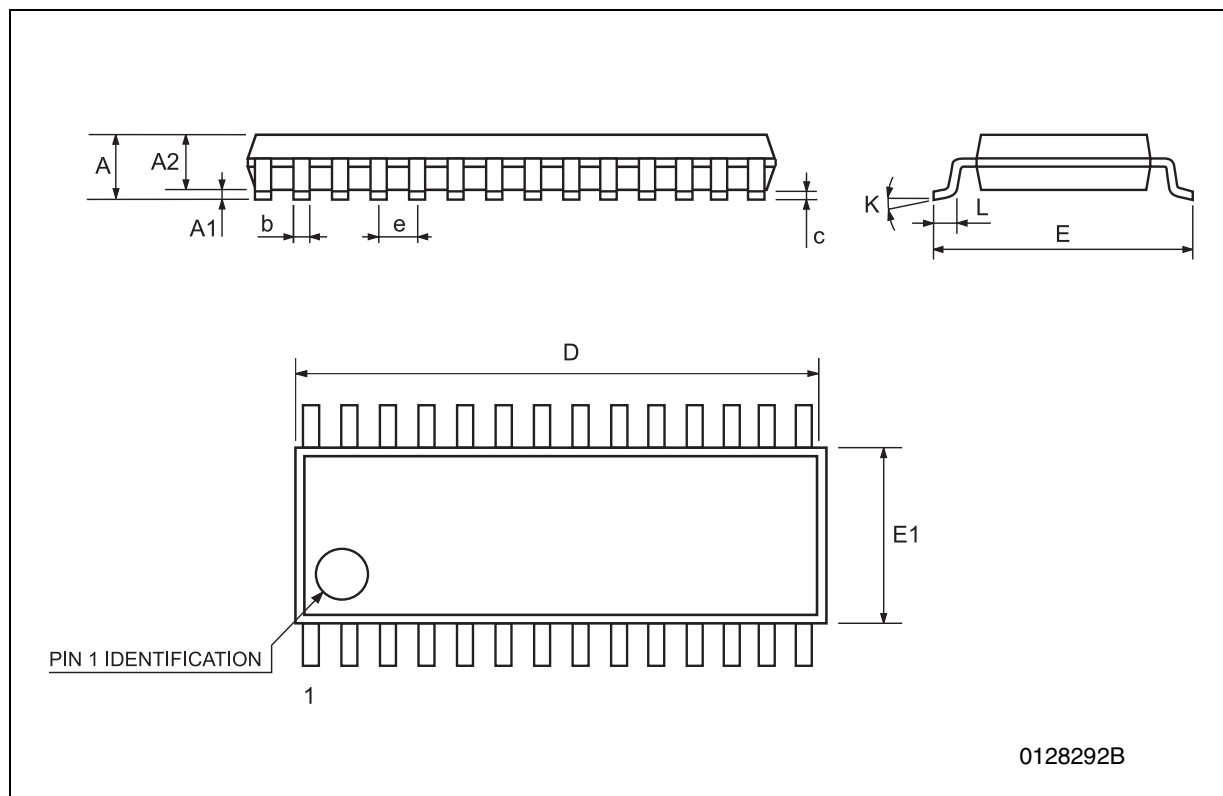

Tape & Reel SO-28 MECHANICAL DATA

| DIM. | mm. | | | inch | | |
|------|------|-----|------|-------|------|--------|
| | MIN. | TYP | MAX. | MIN. | TYP. | MAX. |
| A | | | 330 | | | 12.992 |
| C | 12.8 | | 13.2 | 0.504 | | 0.519 |
| D | 20.2 | | | 0.795 | | |
| N | 60 | | | 2.362 | | |
| T | | | 30.4 | | | 1.197 |
| Ao | 10.8 | | 11.0 | 0.425 | | 0.433 |
| Bo | 18.2 | | 18.4 | 0.716 | | 0.724 |
| Ko | 2.9 | | 3.1 | 0.114 | | 0.122 |
| Po | 3.9 | | 4.1 | 0.153 | | 0.161 |
| P | 11.9 | | 12.1 | 0.468 | | 0.476 |

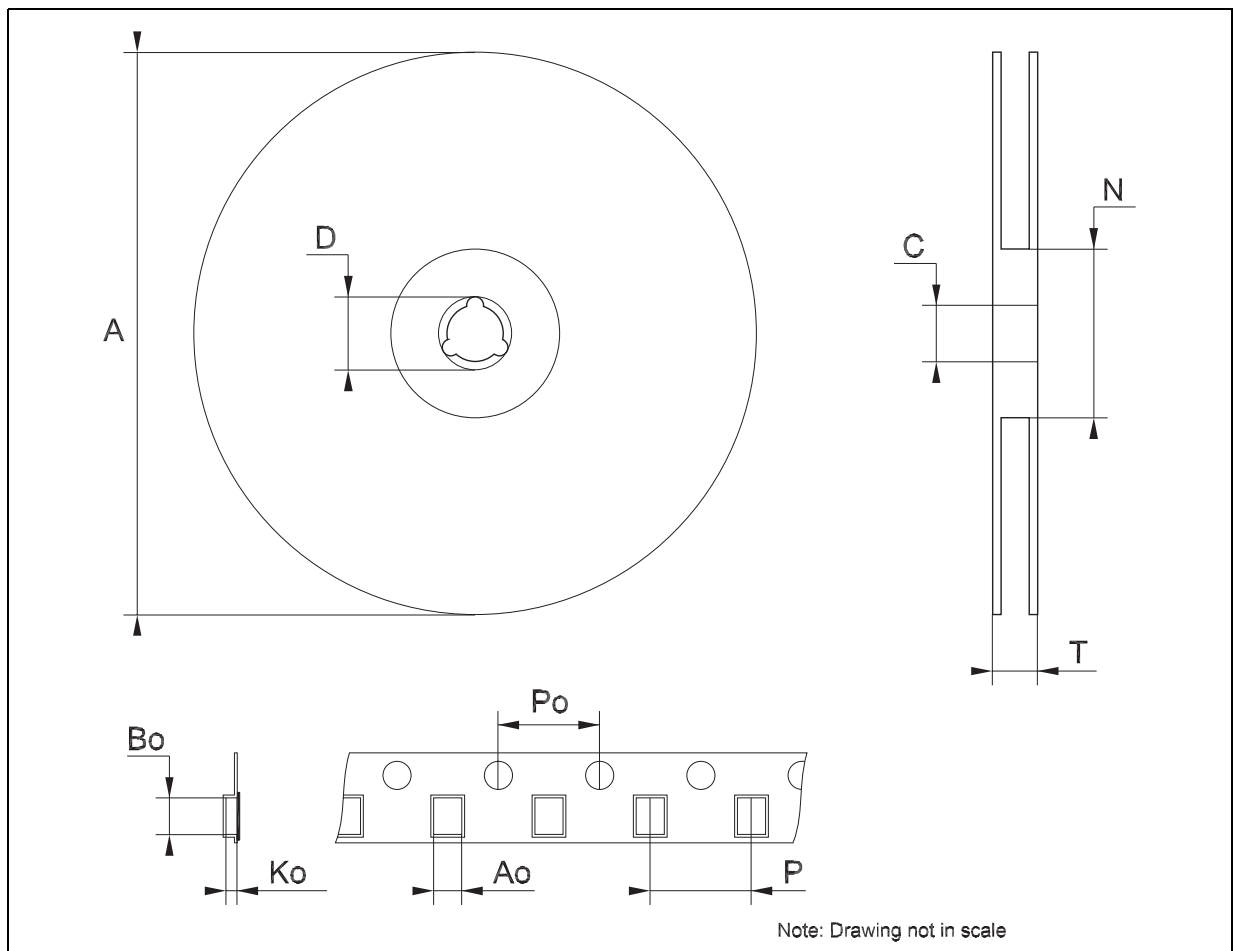

Tape & Reel SO-28 MECHANICAL DATA

| DIM. | mm. | | | inch | | |
|------|------|-----|------|-------|------|--------|
| | MIN. | TYP | MAX. | MIN. | TYP. | MAX. |
| A | | | 330 | | | 12.992 |
| C | 12.8 | | 13.2 | 0.504 | | 0.519 |
| D | 20.2 | | | 0.795 | | |
| N | 60 | | | 2.362 | | |
| T | | | 30.4 | | | 1.197 |
| Ao | 10.8 | | 11.0 | 0.425 | | 0.433 |
| Bo | 18.2 | | 18.4 | 0.716 | | 0.724 |
| Ko | 2.9 | | 3.1 | 0.114 | | 0.122 |
| Po | 3.9 | | 4.1 | 0.153 | | 0.161 |
| P | 11.9 | | 12.1 | 0.468 | | 0.476 |

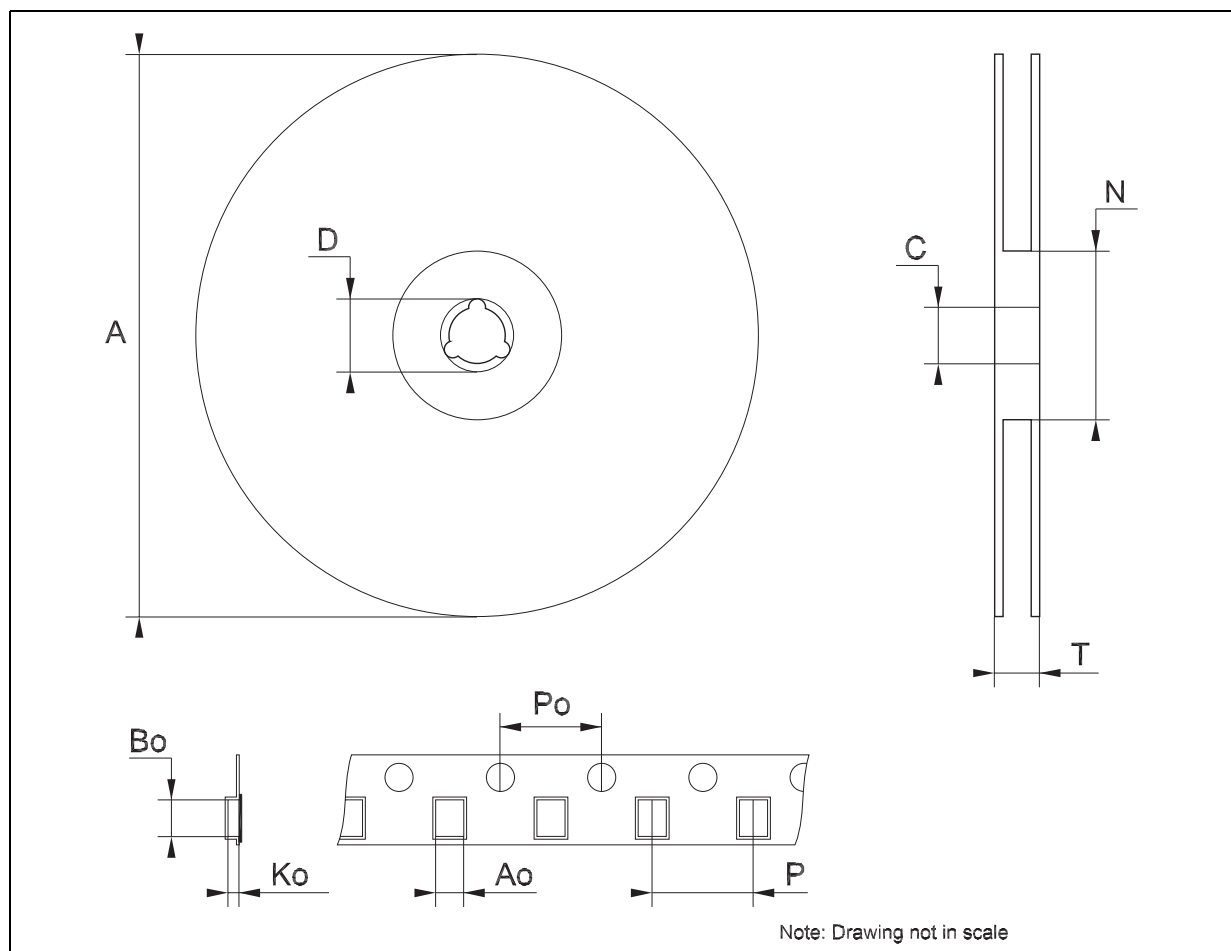

Tape & Reel TSSOP28 MECHANICAL DATA

| DIM. | mm. | | | inch | | |
|------|------|-----|------|-------|------|--------|
| | MIN. | TYP | MAX. | MIN. | TYP. | MAX. |
| A | | | 330 | | | 12.992 |
| C | 12.8 | | 13.2 | 0.504 | | 0.519 |
| D | 20.2 | | | 0.795 | | |
| N | 60 | | | 2.362 | | |
| T | | | 22.4 | | | 0.882 |
| Ao | 6.8 | | 7 | 0.268 | | 0.276 |
| Bo | 10.1 | | 10.3 | 0.398 | | 0.406 |
| Ko | 1.7 | | 1.9 | 0.067 | | 0.075 |
| Po | 3.9 | | 4.1 | 0.153 | | 0.161 |
| P | 11.9 | | 12.1 | 0.468 | | 0.476 |

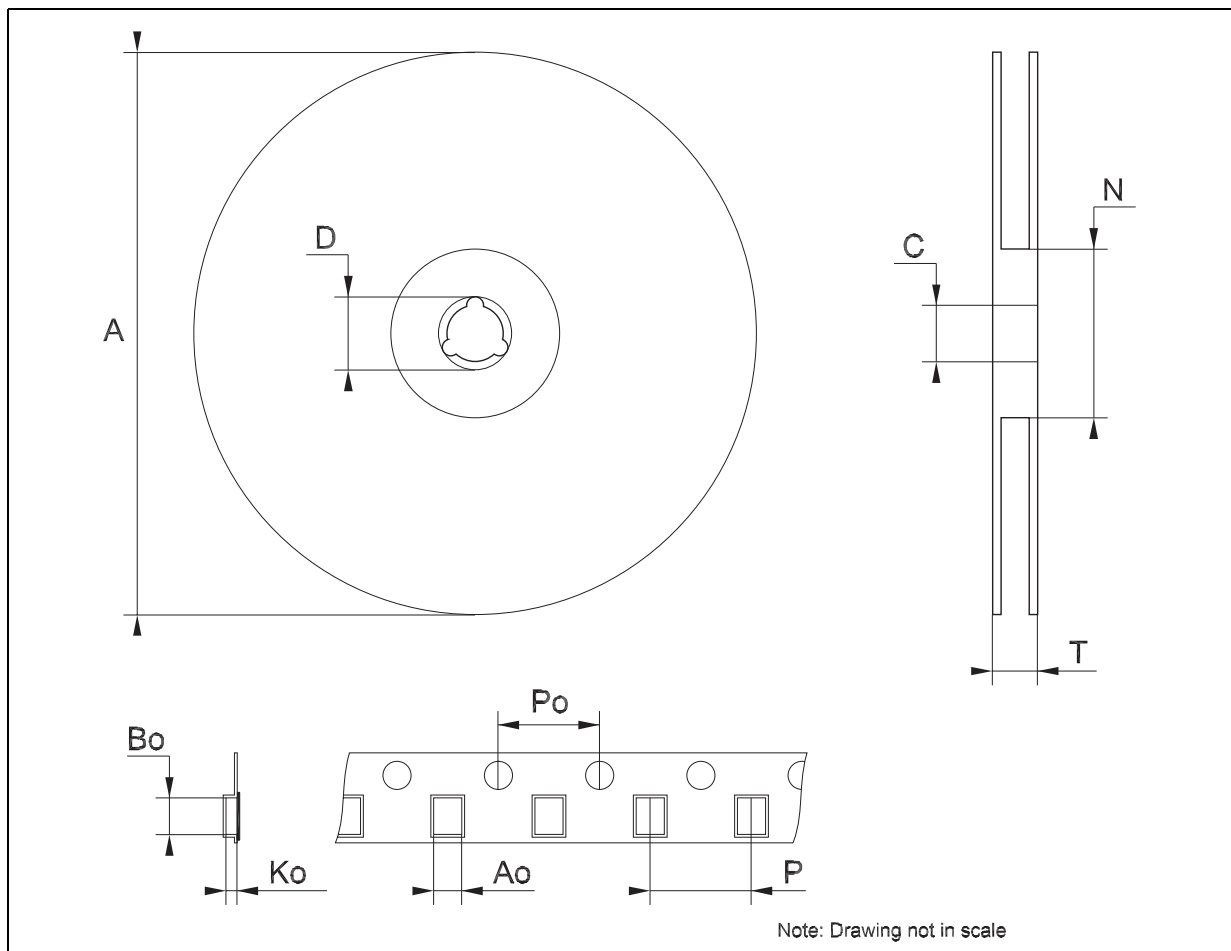

8 Revision history

Table 22. Revision history

| Date | Revision | Changes |
|-------------|----------|--|
| 18-Mar-2004 | 4 | Pag. 10, fig. 4, RSTIN ==> CLK. |
| 27-Jun-2006 | 5 | Add package TSSOP28 and new template. |
| 13-Dec-2006 | 6 | The comment point 5 on page 22 has been removed. |

Please Read Carefully:

Information in this document is provided solely in connection with ST products. STMicroelectronics NV and its subsidiaries ("ST") reserve the right to make changes, corrections, modifications or improvements, to this document, and the products and services described herein at any time, without notice.

All ST products are sold pursuant to ST's terms and conditions of sale.

Purchasers are solely responsible for the choice, selection and use of the ST products and services described herein, and ST assumes no liability whatsoever relating to the choice, selection or use of the ST products and services described herein.

No license, express or implied, by estoppel or otherwise, to any intellectual property rights is granted under this document. If any part of this document refers to any third party products or services it shall not be deemed a license grant by ST for the use of such third party products or services, or any intellectual property contained therein or considered as a warranty covering the use in any manner whatsoever of such third party products or services or any intellectual property contained therein.

UNLESS OTHERWISE SET FORTH IN ST'S TERMS AND CONDITIONS OF SALE ST DISCLAIMS ANY EXPRESS OR IMPLIED WARRANTY WITH RESPECT TO THE USE AND/OR SALE OF ST PRODUCTS INCLUDING WITHOUT LIMITATION IMPLIED WARRANTIES OF MERCHANTABILITY, FITNESS FOR A PARTICULAR PURPOSE (AND THEIR EQUIVALENTS UNDER THE LAWS OF ANY JURISDICTION), OR INFRINGEMENT OF ANY PATENT, COPYRIGHT OR OTHER INTELLECTUAL PROPERTY RIGHT.

UNLESS EXPRESSLY APPROVED IN WRITING BY AN AUTHORIZED ST REPRESENTATIVE, ST PRODUCTS ARE NOT RECOMMENDED, AUTHORIZED OR WARRANTED FOR USE IN MILITARY, AIR CRAFT, SPACE, LIFE SAVING, OR LIFE SUSTAINING APPLICATIONS, NOR IN PRODUCTS OR SYSTEMS WHERE FAILURE OR MALFUNCTION MAY RESULT IN PERSONAL INJURY, DEATH, OR SEVERE PROPERTY OR ENVIRONMENTAL DAMAGE. ST PRODUCTS WHICH ARE NOT SPECIFIED AS "AUTOMOTIVE GRADE" MAY ONLY BE USED IN AUTOMOTIVE APPLICATIONS AT USER'S OWN RISK.

Resale of ST products with provisions different from the statements and/or technical features set forth in this document shall immediately void any warranty granted by ST for the ST product or service described herein and shall not create or extend in any manner whatsoever, any liability of ST.

ST and the ST logo are trademarks or registered trademarks of ST in various countries.

Information in this document supersedes and replaces all information previously supplied.

The ST logo is a registered trademark of STMicroelectronics. All other names are the property of their respective owners.

© 2006 STMicroelectronics - All rights reserved

STMicroelectronics group of companies

Australia - Belgium - Brazil - Canada - China - Czech Republic - Finland - France - Germany - Hong Kong - India - Israel - Italy - Japan - Malaysia - Malta - Morocco - Singapore - Spain - Sweden - Switzerland - United Kingdom - United States of America

www.st.com