



The Future of Analog IC Technology®

MPS CONFIDENTIAL AND PROPRIETARY INFORMATION- INTERNAL USE ONLY

# MP9141

## 1.8A Step-Down DC to DC Converter

### DESCRIPTION

The MP9141 is a monolithic step-down switch mode regulator with a built in internal power MOSFET. It achieves 1.8A continuous output current over a wide input supply range with excellent load and line regulation.

Current mode operation provides fast transient response and eases loop stabilization.

Fault condition protection includes cycle-by-cycle current limiting and thermal shutdown. In shutdown mode the regulator draws 25  $\mu$  A of supply current.

The MP9141 requires a minimum number of readily available standard external components.

### FEATURES

- 1.8A Output Current
- 0.25 $\Omega$  Internal Power MOSFET Switch
- Stable with Low ESR Output Ceramic Capacitors
- Up to 92% Efficiency
- 25 $\mu$ A Shutdown Mode
- Fixed 380KHz Frequency
- Thermal Shutdown
- Cycle-by-Cycle Over Current Protection
- Wide 4.75V to 20V Operating Input Range
- Output Adjustable from 1.22V to 12V
- Programmable Under Voltage Lockout
- Available in an 8-Pin SOIC Package

### APPLICATIONS

- PC Monitors
- Distributed Power Systems
- Battery Charger
- Pre-Regulator for Linear Regulators

"MPS" and "The Future of Analog IC Technology" are Registered Trademarks of Monolithic Power Systems, Inc.

### TYPICAL APPLICATION

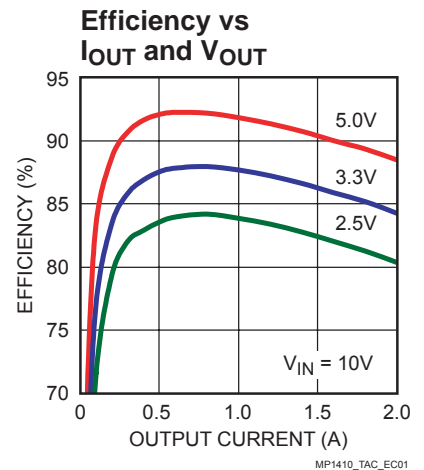
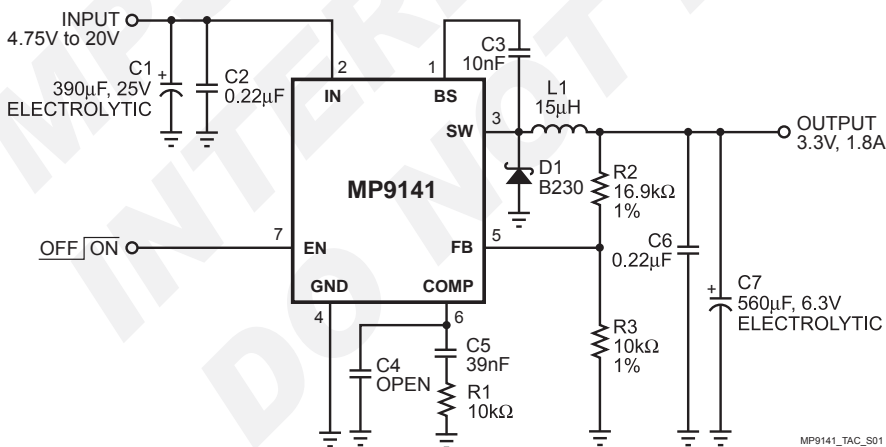

**ORDERING INFORMATION**

Part Number*	Package	Top Marking	Temperature
MP9141ES	SOIC8	MP9141ES	-20°C to +85°C

\* For Tape & Reel, add suffix -Z (eg. MP9141ES-Z).  
 For Lead Free, add suffix -LF (eg. MP9141ES-LF-Z)

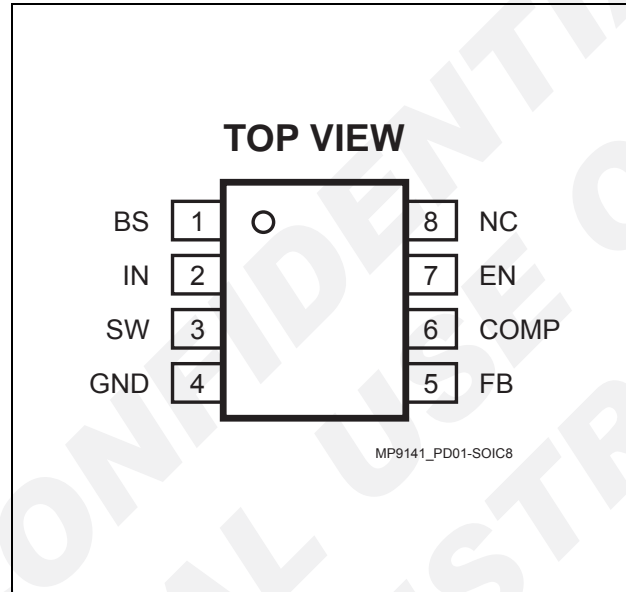
**PACKAGE REFERENCE**

**ABSOLUTE MAXIMUM RATINGS <sup>(1)</sup>**

Input Voltage ( $V_{IN}$ ).....	-0.3V to +22V
Switch Voltage ( $V_{SW}$ ).....	-1V to $V_{IN} + 1V$
Boot Strap Voltage ( $V_{BS}$ ). $V_{SW} - 0.3V$ to $V_{SW} + 6V$	
All Other Pins .....	-0.3 to +6V
Continuous Power Dissipation ( $T_A = +25^\circ C$ ) <sup>(2)</sup>	1.4W
Junction Temperature .....	150°C
Lead Temperature .....	260°C
Storage Temperature.....	-65°C to +150°C

**Recommended Operating Conditions <sup>(3)</sup>**

Input Voltage ( $V_{IN}$ ).....	4.75V to 20V
Maximum Junction Temp. ( $T_J$ ).....	+125°C

Thermal Resistance <sup>(4)</sup>	$\theta_{JA}$	$\theta_{JC}$
SOIC8.....	90	42...°C/W

**Notes:**

- Exceeding these ratings may damage the device.
- The maximum allowable power dissipation is a function of the maximum junction temperature  $T_J$  (MAX), the junction-to-ambient thermal resistance  $\theta_{JA}$ , and the ambient temperature  $T_A$ . The maximum allowable continuous power dissipation at any ambient temperature is calculated by  $P_D$  (MAX) =  $(T_J$  (MAX)- $T_A$ )/ $\theta_{JA}$ . Exceeding the maximum allowable power dissipation will cause excessive die temperature, and the regulator will go into thermal shutdown. Internal thermal shutdown circuitry protects the device from permanent damage.
- The device is not guaranteed to function outside of its operating conditions.
- Measured on JESD51-7, 4-layer PCB.

**ELECTRICAL CHARACTERISTICS**
 **$V_{IN} = 12V$ ,  $V_{EN} = 5V$ ,  $T_A = +25^{\circ}C$ , unless otherwise noted.**

Parameter	Symbol	Condition	Min	Typ	Max	Units
Feedback Voltage		$4.75V \leq V_{IN} \leq 20V$	1.184	1.222	1.258	V
Upper Switch On-Resistance				0.25		$\Omega$
Lower Switch On-Resistance				10		$\Omega$
Upper Switch Leakage		$V_{EN} = 0V$ , $V_{SW} = 0V$			10	$\mu A$
Current Limit			2.4		4.2	A
Oscillator Frequency				380		kHz
Short Circuit Frequency		$V_{FB} = 0V$		42		kHz
Maximum Duty Cycle		$V_{FB} = 1.0V$		90		%
Minimum Duty Cycle		$V_{FB} = 1.5V$			0	%
Enable Threshold			0.7	1.1	1.4	V
Under Voltage Lockout Threshold Rising			2.0	2.5	3.0	V
Under Voltage Lockout Threshold Hysteresis				200		mV
Shutdown Supply Current		$V_{EN} = 0V$		25	50	$\mu A$
Operating Supply Current		$V_{EN} = 5V$ , $V_{FB} = 1.4V$		1.0	1.5	mA
Thermal Shutdown				160		$^{\circ}C$

**PIN FUNCTIONS**

Pin #	Name	Description
1	BS	High-Side Gate Drive Boost Input. BS supplies the drive for the high-side N-Channel MOSFET switch. Connect a 10nF or greater capacitor from SW to BS to power the switch.
2	IN	Power Input. IN supplies the power to the IC, as well as the step-down converter switch. Drive IN with a 4.75V to 20V power source. Bypass IN to GND with a suitably large capacitor to eliminate noise on the input to the IC. See Input Capacitor.
3	SW	Power Switching Output. SW is the switching node that supplies power to the output. Connect the output LC filter from SW to the output load. Note that a capacitor is required from SW to BS to power the high-side switch.
4	GND	Ground.
5	FB	Feedback Input. FB senses the output voltage and regulates it. Drive FB with a resistive voltage divider from the output voltage. The feedback threshold is 1.222V. See Setting the Output Voltage.
6	COMP	Compensation Node. COMP is used to compensate the regulation control loop. Connect a series RC network from COMP to GND to compensate the regulation control loop. See Compensation.
7	EN	Enable Input. EN is a digital input that turns the regulator on or off. Drive EN high to turn on the regulator, low to turn it off. For automatic startup, leave EN unconnected.
8	NC	No Connect.

## OPERATION

The MP9141 is a current-mode step-down switch-mode regulator. It regulates input voltages from 4.75V to 20V down to an output voltage as low as 1.222V and is able to supply up to 1.8A of load current. The MP9141 uses current-mode control to regulate the output voltage. The output voltage is measured at FB through a resistive voltage divider and amplified through the internal error amplifier. The output current of the transconductance error amplifier is presented at COMP where a network compensates the regulation control system. The voltage at COMP is compared to the switch current measured internally to control the output voltage.

The converter uses an internal N-Channel MOSFET switch to step down the input voltage to the regulated output voltage. Since the MOSFET requires a gate voltage greater than the input voltage, a boost capacitor connected between SW and BS drives the gate. The capacitor is internally charged while the switch is off. An internal 10 switch from SW to GND is used to ensure that SW is pulled to GND when the switch is off to fully charge the BS capacitor.

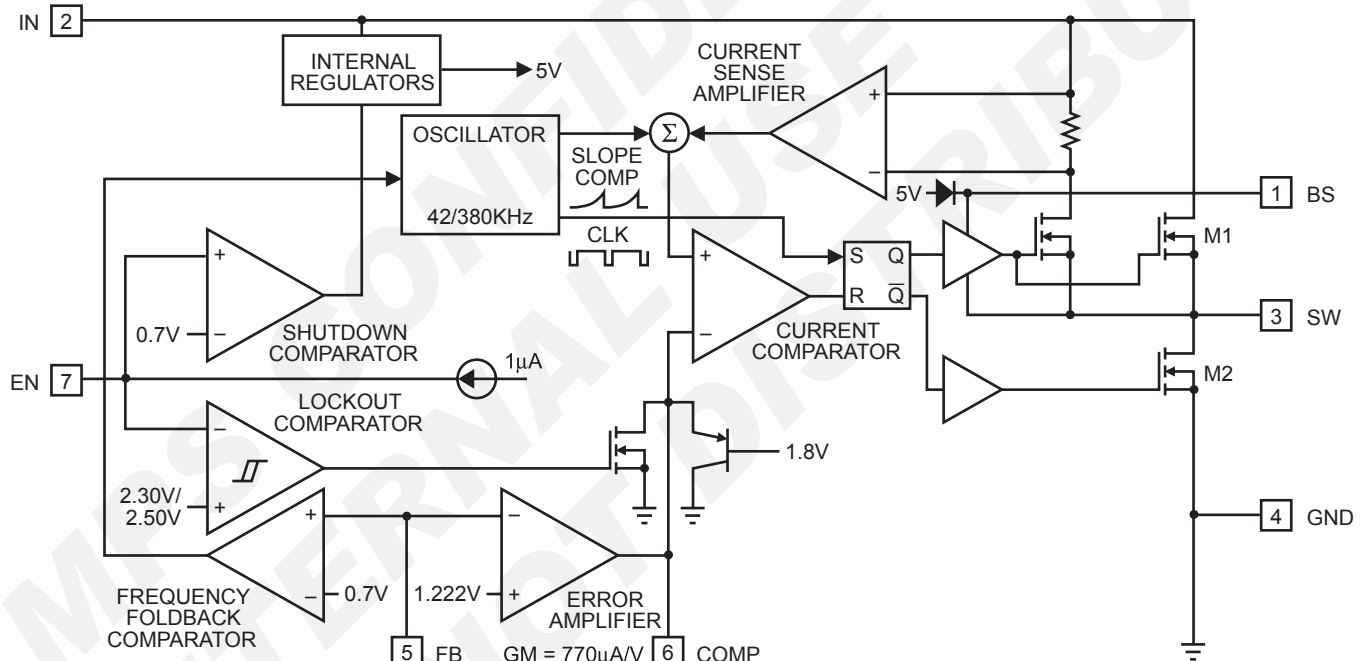

**Figure 1—Functional Block Diagram**

MP9141\_BD01

## APPLICATION INFORMATION

### COMPONENT SELECTION

#### Setting the Output Voltage

The output voltage is set using a resistive voltage divider from the output voltage to FB (see Typical Application circuit on page 1). The voltage divider divides the output voltage down by the equation:

$$V_{FB} = V_{OUT} \times \frac{R3}{(R2 + R3)}$$

Thus the output voltage is:

$$V_{OUT} = 1.222 \times \frac{(R2 + R3)}{R3}$$

R3 can be as high as 100kΩ, but a typical value is 10kΩ. Using that value, R2 is determined by:

$$R2 \cong 8.18 \times (V_{OUT} - 1.222)$$

For example, for a 3.3V output voltage, R3 is 10kΩ, and R2 is 16.9kΩ.

#### Inductor

The inductor is required to supply constant current to the output load while being driven by the switched input voltage. A larger value inductor results in less ripple current that in turn results in lower output ripple voltage. However, the larger value inductor has a larger physical size, higher series resistance and/or lower saturation current. Choose an inductor that does not saturate under the worst-case load conditions. A good rule for determining the inductance is to allow the inductor peak-to-peak ripple current to be approximately 30% of the maximum load current. Also, make sure that the peak inductor current (the load current plus half the peak-to-peak inductor ripple current) is below the 2.4A minimum current limit.

The inductance value can be calculated by the equation:

$$L = V_{OUT} \times \frac{(V_{IN} - V_{OUT})}{(V_{IN} \times f \times \Delta I)}$$

Where  $V_{OUT}$  is the output voltage,  $V_{IN}$  is the input voltage,  $f$  is the switching frequency, and  $\Delta I$  is the peak-to-peak inductor ripple current. Table 1 lists a number of suitable inductors from various manufacturers.

**Table 1—Inductor Selection Guide**

Vendor/Model	Core Type	Core Material	Package Dimensions (mm)		
			W	L	H
<b>Sumida</b>					
CR25	Open	Ferrite	7.0	7.8	5.5
CDH74	Open	Ferrite	7.3	8.0	5.2
CDRH5D28	Shielded	Ferrite	5.5	5.7	5.5
CDRH5D28	Shielded	Ferrite	5.5	5.7	5.5
CDRH6D28	Shielded	Ferrite	6.7	6.7	3.0
CDRH104R	Shielded	Ferrite	10.1	10.0	3.0
<b>Toko</b>					
D53LC Type A	Shielded	Ferrite	5.0	5.0	3.0
D75C	Shielded	Ferrite	7.6	7.6	5.1
D104C	Shielded	Ferrite	10.0	10.0	4.3
D10FL	Open	Ferrite	9.7	11.5	4.0
<b>Coilcraft</b>					
DO3308	Open	Ferrite	9.4	13.0	3.0
DO3316	Open	Ferrite	9.4	13.0	5.1

#### Input Capacitor

The input current to the step-down converter is discontinuous, and therefore an input capacitor C1 is required to supply the AC current to the step-down converter while maintaining the DC input voltage. A low ESR capacitor is required to keep the noise at the IC to a minimum. Ceramic capacitors are preferred, but tantalum or low-ESR electrolytic capacitors may also suffice.

The input capacitor value should be greater than 10μF. The capacitor can be electrolytic, tantalum or ceramic. However, since it absorbs the input switching current it requires an adequate ripple current rating. Its RMS current rating should be greater than approximately 1/2 of the DC load current.

For insuring stable operation C2 should be placed as close to the IC as possible. Alternately a smaller high quality ceramic 0.1μF capacitor may be placed closer to the IC and a larger capacitor placed further away. If using this technique, it is recommended that the larger capacitor be a tantalum or electrolytic type. All ceramic capacitors should be placed close to the MP9141.

### Output Capacitor

The output capacitor is required to maintain the DC output voltage. Low ESR capacitors are preferred to keep the output voltage ripple low. The characteristics of the output capacitor also affect the stability of the regulation control system. Ceramic, tantalum or low ESR electrolytic capacitors are recommended. In the case of ceramic capacitors, the impedance at the switching frequency is dominated by the capacitance and so the output voltage ripple is mostly independent of the ESR. The output voltage ripple is estimated to be:

$$V_{\text{RIPPLE}} \cong 1.4 \times V_{\text{IN}} \times \left( \frac{f_{\text{LC}}}{f} \right)^2$$

Where  $V_{\text{RIPPLE}}$  is the output ripple voltage,  $V_{\text{IN}}$  is the input voltage,  $f_{\text{LC}}$  is the resonant frequency of the LC filter and  $f$  is the switching frequency. In the case of tantalum or low-ESR electrolytic capacitors, the ESR dominates the impedance at the switching frequency, and so the output ripple is calculated as:

$$V_{\text{RIPPLE}} \cong \Delta I \times R_{\text{ESR}}$$

Where  $V_{\text{RIPPLE}}$  is the output voltage ripple,  $\Delta I$  is the inductor ripple current and  $R_{\text{ESR}}$  is the equivalent series resistance of the output capacitors.

### Output Rectifier Diode

The output rectifier diode supplies the current to the inductor when the high-side switch is off. To reduce losses due to the diode forward voltage and recovery times, use a Schottky rectifier.

Table 2 provides the Schottky rectifier part numbers based on the maximum input voltage and current rating.

**Table 2—Schottky Rectifier Selection Guide**

$V_{\text{IN}}$ (Max)	1.8A Load Current	
	Part Number	Vendor
15V	30BQ015	4
20V	B220	1
	SK23	6
	SR32	6

Table 3 lists some rectifier manufacturers.

**Table 3—Schottky Diode Manufacturers**

Vendor	Web Site
Diodes, Inc.	www.diodes.com
Fairchild Semiconductor	www.fairchildsemi.com
General Semiconductor	www.gensemi.com
International Rectifier	www.irf.com
On Semiconductor	www.onsemi.com
Pan Jit International	www.panjit.com.tw

Choose a rectifier whose maximum reverse voltage rating is greater than the maximum input voltage, and has a current rating greater than the maximum load current.

### Compensation

The system stability is controlled through the COMP pin. COMP is the output of the internal transconductance error amplifier. A series capacitor-resistor combination sets a pole-zero combination to control the characteristics of the control system.

The DC loop gain is:

$$A_{\text{VDC}} = \frac{V_{\text{FB}}}{V_{\text{OUT}}} \times A_{\text{VEA}} \times G_{\text{CS}} \times R_{\text{LOAD}}$$

Where  $V_{\text{FB}}$  is the feedback threshold voltage,  $V_{\text{OUT}}$  is the desired output regulation voltage,  $A_{\text{VEA}}$  is the transconductance error amplifier voltage gain,  $G_{\text{CS}}$  is the current sense gain (roughly the output current divided by the voltage at COMP) equal to 1.95 A/V and  $R_{\text{LOAD}}$  is the load resistance ( $V_{\text{OUT}} / I_{\text{OUT}}$  where  $I_{\text{OUT}}$  is the output load current)

The system has two poles of importance, one is due to the compensation capacitor (C5), and the other is due to the output capacitor (C7). These are:

$$f_{\text{P1}} = \frac{G_{\text{EA}}}{2\pi \times A_{\text{VEA}} \times C5}$$

Where P1 is the first pole, and  $G_{\text{EA}}$  is the error amplifier transconductance (770 $\mu$ A/V), and:

$$f_{\text{P2}} = \frac{1}{2\pi \times R_{\text{LOAD}} \times C7}$$

**MPS CONFIDENTIAL AND PROPRIETARY INFORMATION– INTERNAL USE ONLY**

The system has one zero of importance, due to the compensation capacitor (C5) and the compensation resistor (R1). This is:

$$f_{z1} = \frac{1}{2\pi \times R1 \times C5}$$

If a large value capacitor (C7) with relatively high equivalent-series-resistance (ESR) is used, the zero due to the capacitance and ESR of the output capacitor can be compensated by a third pole set by R1 and C4:

$$f_{p3} = \frac{1}{2\pi \times R1 \times C4}$$

The system crossover frequency (the frequency where the loop gain drops to 1 or 0dB) is important. A good standard is to set the crossover frequency to approximately one tenth of the switching frequency. In this case, the switching frequency is 380KHz. Therefore, use a crossover frequency ( $f_c$ ) of 40KHz. Lower crossover frequencies result in slower response and worse transient load recovery. Higher crossover frequencies can result in instability.

**Choosing the Compensation Components**

The values of the compensation components given in Table 4 yield a stable control loop for the output voltage and capacitor given.

**Table 4—Compensation Values for Typical Output Voltage/Capacitor Combinations**

V <sub>OUT</sub>	C7	R1	C5	C4
2.5V	22µF Ceramic	7.5kΩ	2.2nF	None
3.3V	22µF Ceramic	10kΩ	1.5nF	None
5V	22µF Ceramic	10kΩ	2.2nF	None
12V	22µF Ceramic	10kΩ	5.6nF	None
2.5V	560µF/6.3V (30mΩ ESR)	10kΩ	30nF	None
3.3V	560µF/6.3V (30mΩ ESR)	10kΩ	39nF	None
5V	470µF/10V (30mΩ ESR)	10kΩ	47nF	None
12V	220µF/25V (30mΩ ESR)	10kΩ	56nF	None

To optimize the compensation components for conditions not listed in Table 4, use the following procedure:

Choose the compensation resistor to set the desired crossover frequency. Determine the value by the following equation:

$$R1 = 2\pi \times C7 \times V_{OUT} \times \frac{f_c}{(G_{EA} \times G_{CS} \times V_{FB})}$$

Putting in the known constants and setting the crossover frequency to the desired 40KHz:

$$R1 \approx 1.37 \times 10^8 \times C7 \times V_{OUT}$$

The value of R1 is limited to 10kΩ to prevent output overshoot at startup. Therefore, if the value calculated for R1 is greater than 10kΩ, use 10kΩ.

In this case, the actual crossover frequency is less than the desired 40KHz, and is calculated by:

$$f_c = \frac{R1 \times G_{EA} \times G_{CS} \times V_{FB}}{2\pi \times C7 \times V_{OUT}}$$

or:

$$f_c \approx \frac{2.92 \times 10^{-4} \times R1}{C7 \times V_{OUT}}$$

Choose the compensation capacitor to set the zero to one fourth of the crossover frequency.

Determine the value by the following equation:

$$C5 = \frac{0.22 \times C7 \times V_{OUT}}{R1}$$

Determine if the second compensation capacitor, C4 is required. It is required if the ESR zero of the output capacitor occurs at less than four times the crossover frequency.

$$8\pi \times C7 \times R_{ESR} \times f_c \geq 1$$

or:

$$\frac{7.34 \times 10^{-5} \times R1 \times R_{ESR}}{V_{OUT}} \geq 1$$

Where  $R_{ESR}$  is the equivalent series resistance of the output capacitor. If this is the case, add the second compensation capacitor. Determine the value by the equation:

$$C4 = \frac{C7 \times R_{ESR(MAX)}}{R1}$$

Where  $R_{ESR(MAX)}$  is the maximum ESR of the output capacitor.

**For Example:**

$$V_{OUT} = 3.3V$$

$$C7 = 22\mu F \text{ Ceramic (ESR} = 10m\Omega)$$

$$R1 \approx (1.37 \times 10^8) \times (22 \times 10^{-6}) \times 3.3 = 9.9k\Omega$$

Use the nearest standard value of 10k $\Omega$ .

$$C5 \approx \frac{(0.22 \times (22 \times 10^{-6}) \times 3.3)}{10 \times 10^3} = 1.6nF$$

Use the nearest standard value of 1.5nF.

$$2\pi \times C7 \times R_{ESR} \times f_C = 0.014$$

This value is less than 1, therefore no second compensation capacitor is required.

**Negative Output Voltage**

The MP9141 can be configured as a buck-boost converter to generate negative output voltages.

Because the GND pin of the IC is now connected to negative output voltage, the maximum allowable input voltage is the IC input voltage rating (20V) minus the negative output voltage value. A typical application circuit is shown in Figure 2.

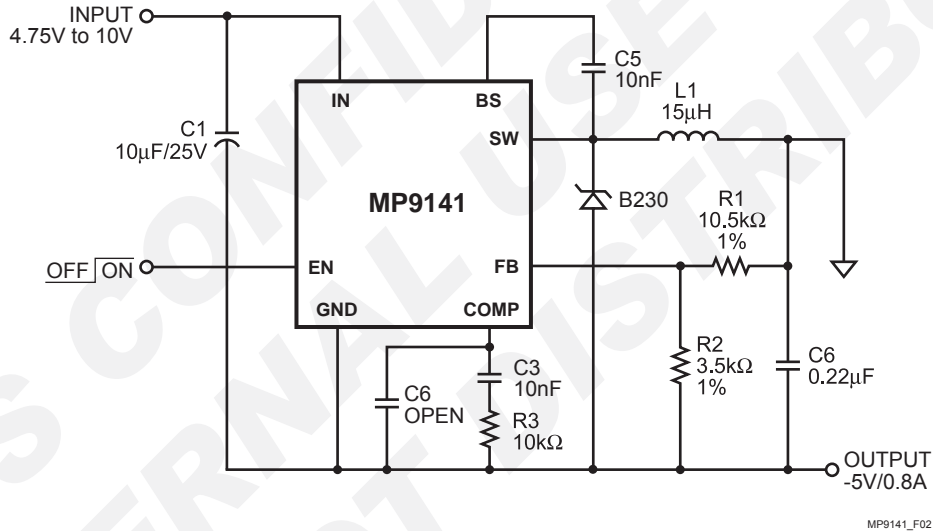
**TYPICAL APPLICATION CIRCUITS**

**Figure 2—Application Circuit for -5V Supply**

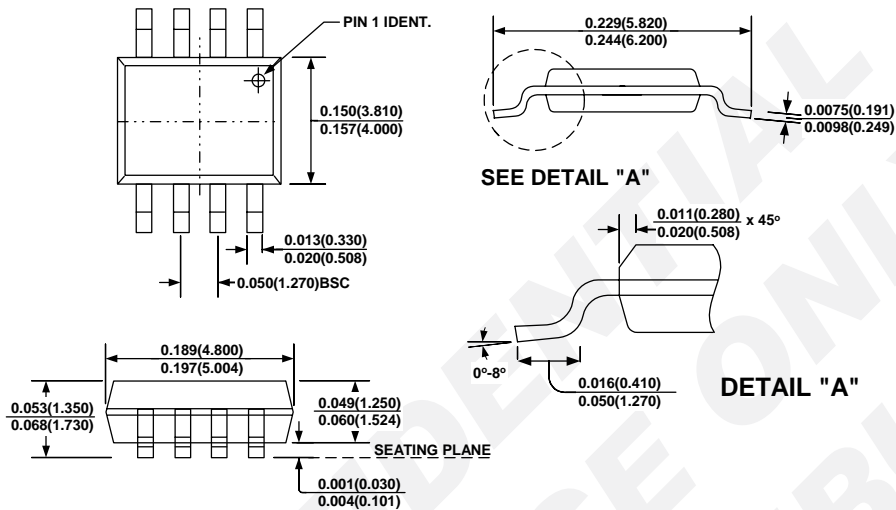
**PACKAGE INFORMATION**
**SOIC8**

**NOTE:**

1) Control dimension is in inches. Dimension in bracket is millimeters.

**NOTICE:** The information in this document is subject to change without notice. Please contact MPS for current specifications. Users should warrant and guarantee that third party Intellectual Property rights are not infringed upon when integrating MPS products into any application. MPS will not assume any legal responsibility for any said applications.