

## Aluminum Electrolytic Capacitors Axial High Temperature, High Ripple Current

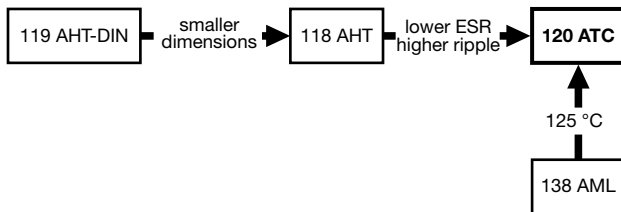


Fig. 1

QUICK REFERENCE DATA	
DESCRIPTION	VALUE
Nominal case sizes (Ø D x L in mm)	10 x 30 to 21 x 38
Rated capacitance range, C <sub>R</sub>	47 µF to 6800 µF
Tolerance on C <sub>R</sub>	± 20 %
Rated voltage range, U <sub>R</sub>	16 V to 100 V
Category temperature range	-40 °C to +125 °C
Endurance test at 150 °C	1000 h
Endurance test at 125 °C	4000 h
Useful life at 125 °C	8000 h
Useful life at 85 °C, 1.4 x I <sub>R</sub> applied	40 000 h
Shelf life at 0 V, 125 °C	1000 h (100 V: 500 h)
Shelf life at 0 V, 150 °C	≤ 63 V: 500 h
Based on sectional specification	IEC 60384-4 / EN 130300
Climatic category IEC 60068	40 / 125 / 56

### FEATURES

- Extra long useful life: up to 8000 h at 125 °C
- Extended temperature range: usable up to 150 °C
- Low ESR levels provide very high ripple current capability
- Miniaturized, high CV-product per unit volume
- Polarized aluminum electrolytic capacitors, non-solid electrolyte
- Axial leads, cylindrical aluminum case, insulated with a blue sleeve
- Taped versions up to case Ø 15 mm x 30 mm available for automatic insertion
- Lead diameter Ø d = 1.0 mm, available on request
- AEC-Q200 qualified
- Material categorization: for definitions of compliance please see [www.vishay.com/doc?99912](http://www.vishay.com/doc?99912)


**RoHS  
COMPLIANT**

### APPLICATIONS

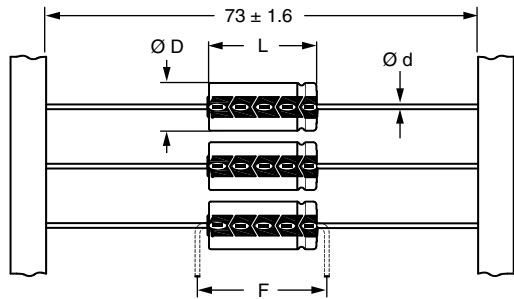
- Automotive, industrial, and telecommunication
- Smoothing, filtering, buffering
- Low mounting height applications, vibration and shock resistant
- SMPS and standard power supplies

### MARKING

The capacitors are marked (where possible) with the following information:

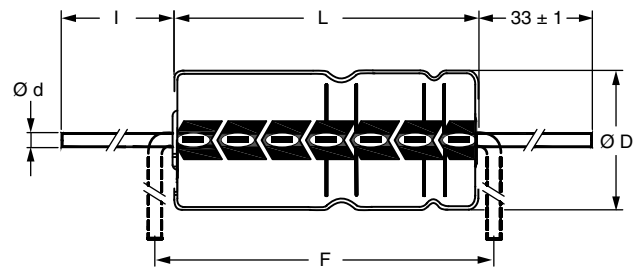
- Rated capacitance (in µF)
- Tolerance on rated capacitance, code letter in accordance with IEC 60062 (M for ± 20 %)
- Rated voltage (in V)
- Upper category temperature (125 °C)
- Date code in accordance with IEC 60062
- Code for factory of origin
- Name of manufacturer
- Negative terminal identification
- Series number (120)

SELECTION CHART FOR C <sub>R</sub> , U <sub>R</sub> , AND RELEVANT NOMINAL CASE SIZE (Ø D x L in mm)					
C <sub>R</sub> (µF)	U <sub>R</sub> (V)				
	16	25	40	63	100
47	-	-	-	-	10 x 30
68	-	-	-	-	12.5 x 30
100	-	-	-	10 x 30	12.5 x 30
150	-	-	-	12.5 x 30	15 x 30
220	-	-	10 x 30	12.5 x 30	18 x 30
330	-	-	12.5 x 30	15 x 30	18 x 38
470	-	10 x 30	12.5 x 30	18 x 30	21 x 38
680	10 x 30	12.5 x 30	15 x 30	18 x 38	-
1000	12.5 x 30	12.5 x 30	18 x 30	21 x 38	-
1500	12.5 x 30	15 x 30	18 x 38	-	-
2200	15 x 30	18 x 30	21 x 38	-	-
3300	18 x 30	18 x 38	-	-	-
4700	18 x 38	21 x 38	-	-	-
6800	21 x 38	-	-	-	-

**DIMENSIONS in millimeters AND AVAILABLE FORMS**


**Form BR:** Taped on reel  
Case  $\varnothing D \times L = 6.5 \text{ mm} \times 18 \text{ mm}$  to  $15 \text{ mm} \times 30 \text{ mm}$

Fig. 2 - Form BR



**Form AA:** Axial in box  
Case  $\varnothing D \times L = 10 \text{ mm} \times 30 \text{ mm}$  to  $21 \text{ mm} \times 38 \text{ mm}$

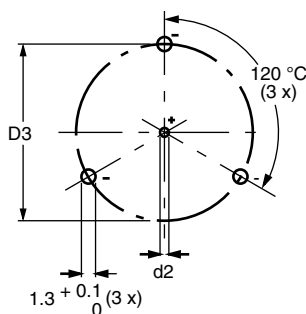
Fig. 3 - Form AA

Table 1

<b>AXIAL; DIMENSIONS in millimeters, MASS, AND PACKAGING QUANTITIES</b>								
NOMINAL CASE SIZE $\varnothing D \times L$ (mm)	AXIAL: FORM AA AND BR					MASS (g)	PACKAGING QUANTITIES	
	$\varnothing d$ (1)	I	$\varnothing D_{\text{max.}}$	$L_{\text{max.}}$	$F_{\text{min.}}$		FORM AA	FORM BR
10 x 30	0.8	$55 \pm 1$	10.5	30.5	35	$\approx 4.8$	340	500
12.5 x 30	0.8	$55 \pm 1$	13.0	30.5	35	$\approx 7.4$	260	400
15 x 30	0.8	$55 \pm 1$	15.5	30.5	35	$\approx 11.7$	200	250
18 x 30	0.8	$55 \pm 1$	18.5	30.5	35	$\approx 12.9$	120	-
18 x 38	0.8	$34 \pm 1$	18.5	39.5	44	$\approx 19.0$	125	-
21 x 38	0.8	$34 \pm 1$	21.5	39.5	44	$\approx 24.0$	100	-

**Notes**

- For detailed tape dimensions, please see [www.vishay.com/doc?28361](http://www.vishay.com/doc?28361)
- (1) Lead diameter  $\varnothing d = 1.0 \text{ mm}$ , available on request



Mounting holes

Case  $\varnothing D \times L = 15 \text{ mm} \times 30 \text{ mm}$  to  $21 \text{ mm} \times 38 \text{ mm}$   
Especially for applications with severe shocks and vibrations

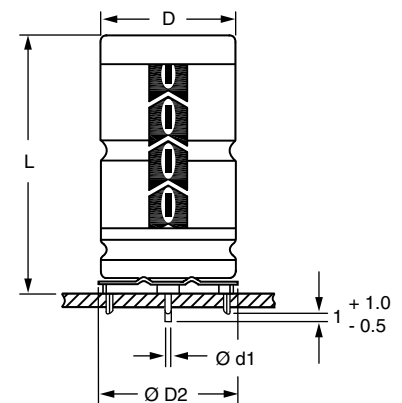
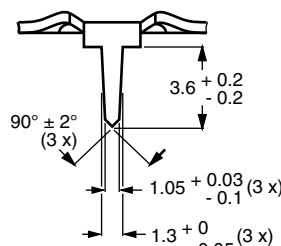

 Fig. 4 - Mounting hole diagram and outline; **form MR:** With mounting ring and pins

Table 2

<b>MOUNTING RING; DIMENSIONS in millimeters, MASS, AND PACKAGING QUANTITIES</b>									
NOMINAL CASE SIZE $\varnothing D \times L$	CASE CODE	MOUNTING RING: FORM MR						MASS (g)	PACKAGING QUANTITIES
		$\varnothing d1$	$\varnothing d2$	$\varnothing D_{\text{max.}}$	$\varnothing D2_{\text{max.}}$	D3	$L_{\text{max.}}$		
15 x 30	02	0.8	$1.0 + 0.4$	15.5	17.5	$16.5 \pm 0.2$	33	$\approx 8.6$	200
18 x 30	03	0.8	$1.0 + 0.4$	18.5	19.5	$18.5 \pm 0.2$	33	$\approx 11.5$	240
18 x 38	04	0.8	$1.0 + 0.4$	18.5	19.5	$18.5 \pm 0.2$	42	$\approx 14.0$	100
21 x 38	05	0.8	$1.0 + 0.4$	21.5	22.5	$21.5 \pm 0.2$	42	$\approx 19.2$	100



ELECTRICAL DATA	
SYMBOL	DESCRIPTION
$C_R$	Rated capacitance at 100 Hz, tolerance $\pm 20\%$
$I_R$	Rated RMS ripple current at 10 kHz, 125 °C
$I_{L1}$	Max. leakage current after 1 min at $U_R$
$I_{L5}$	Max. leakage current after 5 min at $U_R$
ESR	Equivalent series resistance at 100 Hz (calculated from $\tan \delta_{max}$ and $C_R$ )
Z	Max. impedance at 10 kHz

**Note**

- Unless otherwise specified, all electrical values in Table 3 apply at  $T_{amb} = 20\text{ °C}$ ,  $P = 86\text{ kPa}$  to  $106\text{ kPa}$ ,  $RH = 45\%$  to  $75\%$

**ORDERING EXAMPLE**

Electrolytic capacitor 120 series

1000  $\mu\text{F}$  / 16 V;  $\pm 20\%$

Nominal case size:  $\varnothing 12.5\text{ mm} \times 30\text{ mm}$ ; form BR

Ordering code: MAL212025102E3

Former 12NC: 2222 120 25102

**Table 3**

ELECTRICAL DATA AND ORDERING INFORMATION														
$U_R$ (V)	$C_R$ 100 Hz ( $\mu\text{F}$ )	NOMINAL CASE SIZE $\varnothing D \times L$ (mm)	$I_R$ 10 kHz 125 °C (mA)	$I_{L1}$ 1 min ( $\mu\text{A}$ )	$I_{L5}$ 5 min ( $\mu\text{A}$ )	TYP. ESR 100 Hz (m $\Omega$ )	MAX. ESR 100 Hz (m $\Omega$ )	TYP. ESR 10 kHz (m $\Omega$ )	MAX. ESR 10 kHz (m $\Omega$ )	Z MAX. 10 kHz (m $\Omega$ )	FREQ. CODE <sup>(1)</sup>	ORDERING CODE MAL2120.....		
												IN BOX FORM AA	TAPED ON REEL FORM BR	MOUNTING RING FORM MR
16	680	10 x 30	2100	171	84	106	177	44	74	78	MF1	15681E3	25681E3	-
	1000	12.5 x 30	2550	232	104	77	128	35	58	61	MF1	15102E3	25102E3	-
	1500	12.5 x 30	2650	328	136	60	100	32	53	53	MF1	15152E3	25152E3	-
	2200	15 x 30	2940	462	181	48	79	28	46	46	MF1	15222E3	25222E3	45222E3
	3300	18 x 30	3430	674	251	41	68	26	43	43	MF2	15332E3	-	45332E3
	4700	18 x 38	4350	942	341	27	45	18	29	29	MF2	15472E3	-	45472E3
	6800	21 x 38	4590	1346	475	26	43	18	29	29	MF2	15682E3	-	45682E3
25	470	10 x 30	2100	181	87	112	187	45	74	84	MF1	16471E3	26471E3	-
	680	12.5 x 30	2550	244	108	81	136	35	59	64	MF1	16681E3	26681E3	-
	1000	12.5 x 30	2600	340	140	64	107	32	53	55	MF1	16102E3	26102E3	-
	1500	15 x 30	2890	490	190	49	82	28	46	46	MF1	16152E3	26152E3	46152E3
	2200	18 x 30	3310	700	260	43	71	27	44	44	MF2	16222E3	-	46222E3
	3300	18 x 38	4350	1030	370	28	47	18	29	29	MF2	16332E3	-	46332E3
	4700	21 x 38	4470	1450	510	27	44	18	29	29	MF2	16472E3	-	46472E3
40	220	10 x 30	1990	146	75	192	320	52	87	124	MF1	17221E3	27221E3	-
	330	12.5 x 30	2430	198	93	130	216	37	62	83	MF1	17331E3	27331E3	-
	470	12.5 x 30	2550	266	115	101	169	35	58	70	MF1	17471E3	27471E3	-
	680	15 x 30	2840	366	149	75	125	30	50	55	MF1	17681E3	27681E3	47681E3
	1000	18 x 30	3150	520	200	59	99	28	47	49	MF2	17102E3	-	47102E3
	1500	18 x 38	4130	760	280	39	65	19	31	32	MF2	17152E3	-	47152E3
	2200	21 x 38	4170	1096	392	34	56	19	31	31	MF2	17222E3	-	47222E3
63	100	10 x 30	1560	116	65	297	495	92	154	249	MF3	18101E3	28101E3	-
	150	12.5 x 30	2050	153	78	195	325	61	102	162	MF3	18151E3	28151E3	-
	220	12.5 x 30	2150	206	95	149	249	55	92	126	MF3	18221E3	28221E3	-
	330	15 x 30	2510	289	123	105	175	44	73	91	MF3	18331E3	28331E3	48331E3
	470	18 x 30	2860	395	158	81	135	38	64	74	MF4	18471E3	-	48471E3
	680	18 x 38	3720	554	211	55	92	26	43	49	MF4	18681E3	-	48681E3
	1000	21 x 38	3780	796	292	44	74	25	41	43	MF4	18102E3	-	48102E3
100	47	10 x 30	760	96	59	760	1269	349	581	720	MF3	19479E3	29479E3	-
	68	12.5 x 30	1030	122	67	531	885	246	410	503	MF3	19689E3	29689E3	-
	100	12.5 x 30	1140	160	80	389	648	196	327	381	MF3	19101E3	29101E3	-
	150	15 x 30	1480	220	100	266	443	137	229	262	MF3	19151E3	29151E3	49151E3
	220	18 x 30	1960	304	128	181	302	95	158	179	MF4	19221E3	-	49221E3
	330	18 x 38	2550	436	172	120	200	62	104	117	MF4	19331E3	-	49331E3
	470	21 x 38	2800	604	228	92	154	52	86	94	MF4	19471E3	-	49471E3

**Note**

- <sup>(1)</sup> Determines the applicable row in the table "Multiplier of Ripple Current ( $I_R$ ) as a Function of Frequency"

ADDITIONAL ELECTRICAL DATA			
PARAMETER	CONDITIONS	VALUE	
		AXIAL	MOUNTING RING
<b>Voltage</b>			
Surge voltage		$U_s \leq 1.15 \times U_R$	
Reverse voltage		$U_{rev} \leq 1 \text{ V}$	
<b>Current</b>			
Leakage current	After 1 min at $U_R$	$I_{L1} \leq 0.012 C_R \times U_R + 40 \mu\text{A}$	
	After 5 min at $U_R$	$I_{L5} \leq 0.004 C_R \times U_R + 40 \mu\text{A}$	
<b>Inductance</b>			
Equivalent series inductance (ESL)	Case $\varnothing$ D x L mm:		
	10 x 30	Typ. 38 nH	
	12.5 x 30	Typ. 46 nH	
	15 x 30	Typ. 48 nH	Typ. 39 nH
	18 x 30	Typ. 50 nH	Typ. 39 nH
	18 x 38	Typ. 54 nH	Typ. 39 nH
	21 x 38	Typ. 59 nH	Typ. 39 nH

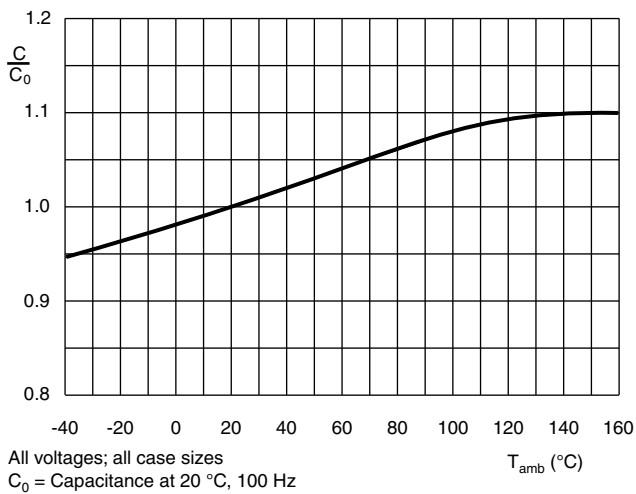
**CAPACITANCE (C)**


Fig. 5 - Typical multiplier of capacitance as a function of ambient temperature

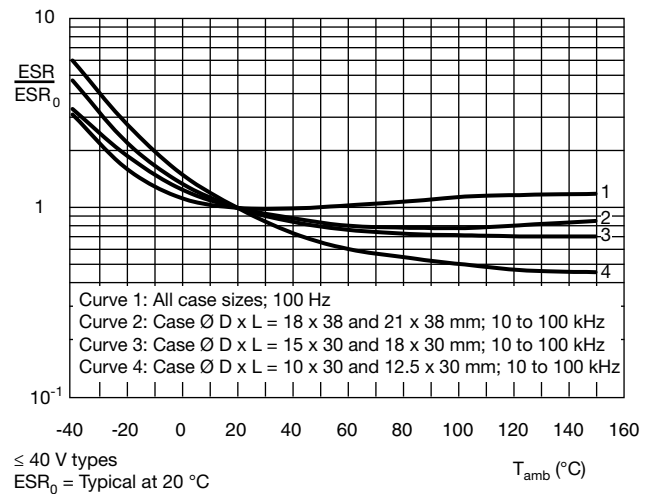
**EQUIVALENT SERIES RESISTANCE (ESR)**


Fig. 6 - Typical multiplier of ESR as a function of ambient temperature at different frequencies

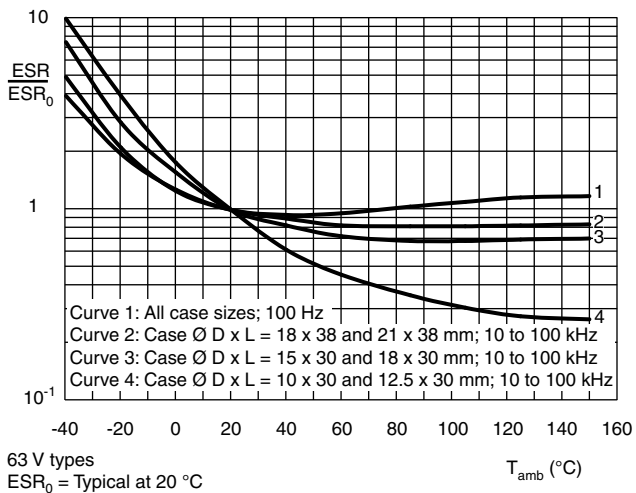


Fig. 7 - Typical multiplier of ESR as a function of ambient temperature at different frequencies

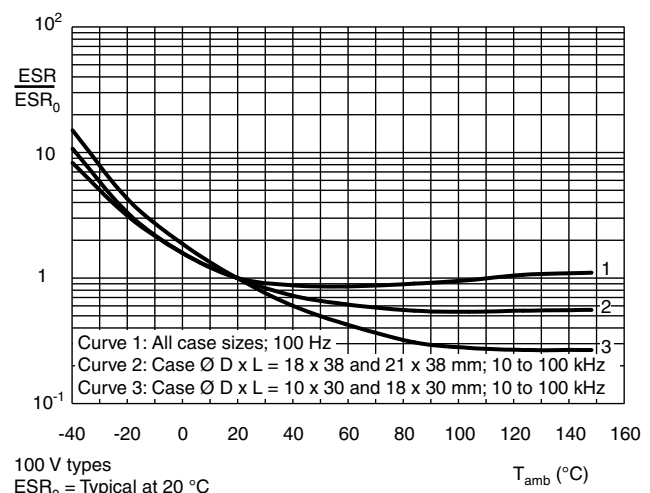


Fig. 8 - Typical multiplier of ESR as a function of ambient temperature at different frequencies

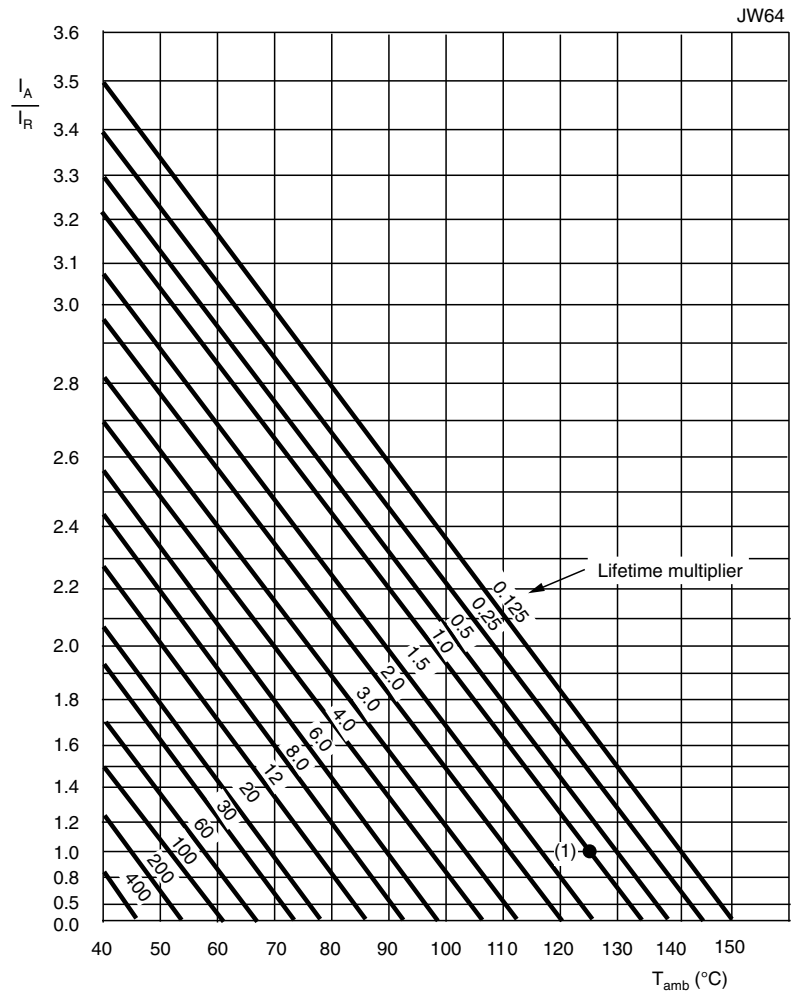
**RIPPLE CURRENT AND USEFUL LIFE**

Table 4

ENDURANCE TEST DURATION AND USEFUL LIFE	
ENDURANCE AT 125 °C (h)	USEFUL LIFE AT 125 °C (h)
4000	8000

**Note**

- Multiplier of useful life code: JW64


 $I_A$  = Actual ripple current at 10 kHz

 $I_R$  = Rated ripple current at 10 kHz, 125 °C

 (1) Useful life at 125 °C and  $I_R$  applied: 8000 h

Fig. 9 - Multiplier of useful life as a function of ambient temperature and ripple current load

Table 5

MULTIPLIER OF RIPPLE CURRENT ( $I_R$ ) AS A FUNCTION OF FREQUENCY						
FREQ. CODE	FREQUENCY (Hz)					
	50	100	300	1000	3000	≥ 10 000
$I_R$ MULTIPLIER						
MF1	0.37	0.48	0.69	0.86	0.96	1.00
MF2	0.54	0.63	0.75	0.81	0.87	1.00
MF3	0.23	0.32	0.53	0.77	0.93	1.00
MF4	0.44	0.56	0.76	0.88	0.94	1.00

Table 6

TEST PROCEDURES AND REQUIREMENTS			
TEST		PROCEDURE (quick reference)	REQUIREMENTS
NAME OF TEST	REFERENCE		
Endurance	IEC 60384-4 / EN 130300 subclause 4.13	$T_{amb} = 125\text{ °C}$ ; $U_R$ applied; 4000 h  $T_{amb} = 150\text{ °C}$ ; $U_R$ applied; 1000 h	$\Delta C/C$ : $\pm 15\%$ $\tan \delta \leq 1.3 \times \text{spec. limit}$ $Z \leq 2 \times \text{spec. limit}$ $I_{L5} \leq \text{spec. limit}$
Useful life	CECC 30301 subclause 1.8.1	$T_{amb} = 125\text{ °C}$ ; $U_R$ and $I_R$ applied; 8000 h	$\Delta C/C$ : $\pm 45\%$ $\tan \delta \leq 3 \times \text{spec. limit}$ $Z \leq 3 \times \text{spec. limit}$ $I_{L5} \leq \text{spec. limit}$ no short or open circuit total failure percentage: $\leq 1\%$
Shelf life (storage at high temperature)	IEC 60384-4 / EN 130300 subclause 4.17	$T_{amb} = 125\text{ °C}$ ; no voltage applied; 1000 h (100 V: 500 h)  $T_{amb} = 150\text{ °C}$ ; no voltage applied; 500 h for voltages: $\leq 63\text{ V}$  After test: $U_R$ to be applied for 30 min, 24 h to 48 h before measurement	$\Delta C/C$ , $\tan \delta$ , $Z$ : for requirements see "Endurance test" above $I_{L5} \leq 2 \times \text{spec. limit}$
Reverse voltage	IEC 60384-4 / EN 130300 subclause 4.15	$T_{amb} = 125\text{ °C}$ : 125 h at $U = -1\text{ V}$ Followed by 125 h at $U_R$	$\Delta C/C$ : $\pm 20\%$ $\tan \delta \leq \text{spec. limit}$ $I_{L5} \leq \text{spec. limit}$

Statements about product lifetime are based on calculations and internal testing. They should only be interpreted as estimations. Also due to external factors, the lifetime in the field application may deviate from the calculated lifetime. In general, nothing stated herein shall be construed as a guarantee of durability.



## **Disclaimer**

ALL PRODUCT, PRODUCT SPECIFICATIONS AND DATA ARE SUBJECT TO CHANGE WITHOUT NOTICE TO IMPROVE RELIABILITY, FUNCTION OR DESIGN OR OTHERWISE.

Vishay Intertechnology, Inc., its affiliates, agents, and employees, and all persons acting on its or their behalf (collectively, "Vishay"), disclaim any and all liability for any errors, inaccuracies or incompleteness contained in any datasheet or in any other disclosure relating to any product.

Vishay makes no warranty, representation or guarantee regarding the suitability of the products for any particular purpose or the continuing production of any product. To the maximum extent permitted by applicable law, Vishay disclaims (i) any and all liability arising out of the application or use of any product, (ii) any and all liability, including without limitation special, consequential or incidental damages, and (iii) any and all implied warranties, including warranties of fitness for particular purpose, non-infringement and merchantability.

Statements regarding the suitability of products for certain types of applications are based on Vishay's knowledge of typical requirements that are often placed on Vishay products in generic applications. Such statements are not binding statements about the suitability of products for a particular application. It is the customer's responsibility to validate that a particular product with the properties described in the product specification is suitable for use in a particular application. Parameters provided in datasheets and / or specifications may vary in different applications and performance may vary over time. All operating parameters, including typical parameters, must be validated for each customer application by the customer's technical experts. Product specifications do not expand or otherwise modify Vishay's terms and conditions of purchase, including but not limited to the warranty expressed therein.

Hyperlinks included in this datasheet may direct users to third-party websites. These links are provided as a convenience and for informational purposes only. Inclusion of these hyperlinks does not constitute an endorsement or an approval by Vishay of any of the products, services or opinions of the corporation, organization or individual associated with the third-party website. Vishay disclaims any and all liability and bears no responsibility for the accuracy, legality or content of the third-party website or for that of subsequent links.

Vishay products are not designed for use in life-saving or life-sustaining applications or any application in which the failure of the Vishay product could result in personal injury or death unless specifically qualified in writing by Vishay. Customers using or selling Vishay products not expressly indicated for use in such applications do so at their own risk. Please contact authorized Vishay personnel to obtain written terms and conditions regarding products designed for such applications.

No license, express or implied, by estoppel or otherwise, to any intellectual property rights is granted by this document or by any conduct of Vishay. Product names and markings noted herein may be trademarks of their respective owners.